



**BriSCA Formula 2 Stock Cars**  
**2023** Driver Information and  
**Technical Car Specification Regulations**

**Part – 2**

**Technical Car Specification Regulations**

**Chapter – 12**

***v2023.01 – Published 3<sup>rd</sup> Mar 2023***

© 2023, BriSCA F2 Ltd. All rights reserved.

The unauthorised copying, publication, or use of this document, or parts thereof, is strictly prohibited.

# CONTENTS

200	General Regulations .....	4
201	BriSCA Formula 2 Stock Car Definition .....	5
202	Weight and Ballast .....	5
203	Chassis Construction .....	6
204	Bumpers .....	12
205	Nerf-Rails.....	16
206	Wheel-Guards.....	18
207	Engine Firewall .....	19
208	Floors and Side-Pods.....	19
209	Foot Protection Plating.....	21
210	Driver's Seating & Harness .....	21
211	Foot Pedals.....	23
212	Track Width.....	24
213	Suspension – Shock Absorbers (Dampers) and Springs.....	24
214	Front Axle/Suspension .....	25
215	Rear Axle/Suspension.....	26
216	Wheel Rims and Wheel-Nuts .....	27
217	Tyres .....	28
218	Brakes .....	29
219	Transmission/Final Drive.....	30
220	Batteries & Electrical .....	31
221	Radiators and Cooling System .....	32
222	Fuel and Fuel System .....	32
223	Exhaust System and Silencer – All Engine Types.....	34
225	Fire Extinguishers .....	36
226	Aerofoils/Spoilers/Wings .....	36
227	Transponders.....	38
228	Driver/Car Identification.....	39
229	Grading Colours/Roof Painting/Lights.....	39
230	Engines – General Regulations For ALL Engines .....	40
231	Engines – Ford 2.0-litre SOHC NE (Pinto) Specification .....	42
233	Engines – Ford 2.0-Litre 16v Zetec Specification.....	49
234	Safety Equipment.....	62

# CHAPTER 12

## BriSCA Formula Two

### **2023** Technical Car Specification Regulations

**Note:** All changes from the previously published version of the Technical Car Specification Regulations are highlighted in **red italics**. Any regulations that are no longer applicable are marked in ~~Strikethrough~~ text.

#### Definitions used in these Regulations

RHS	Rectangular Hollow Section
SHS	Square Hollow Section
CHS	Circular Hollow Section
OHS	Oval Hollow Section
Axle	A solid axle with a wheel at each end (e.g. a front beam axle, or English rear axle), or both sides of an independent suspension arrangement taken as a pair (e.g. a wishbone/bottom arm front suspension design).
Car centre-line	The main centre-line of the car is defined as a line running along the horizontal length of the car, equidistant between the two main chassis rails when viewed from above.
Engine centre-line	The centre-line of the engine is defined as the rotational centre-line of the crankshaft, measured at the pulley securing bolt.
Front Edge of Driver's Seat	The front edge of the driver's seat is defined as the transverse front edge of the seat, behind the driver's knees, not including any leg side-supports/bracing.
Standard Type/Size	Component of a size, weight and material as originally manufactured. Details can normally be found in the appropriate Haynes manual.
Production Type/Size	Component of a size, weight and material as originally manufactured. Details can normally be found in the appropriate Haynes manual.
Original Type/Size	Component of a size, weight and material as originally manufactured. Details can normally be found in the appropriate Haynes manual.
TDC	Top Dead Centre
ECU	Electronic Control Unit
OEM	Original Equipment Manufacturer

#### General Notes

- It is the driver's responsibility to present a **safe and legal** car **at all times** (including scrutineering, practise, and racing). This is stressed especially for such simple checks as front wishbone lengths, bumper heights, track width, and rear axle alignment.
- The presentation of a car for scrutineering is a declaration by the driver that the car is eligible to race, and complies with all technical and safety regulations.
- Any necessary regulation changes during the course of a season (most likely to be safety related) will be notified to drivers through the official BriSCA F2 website (BriSCAf2.com). Change advisories received from any other source should be checked against this official source for authenticity and accuracy.
- Drivers are welcome to submit proposed changes to regulations, to BriSCA F2, where the opportunity of a safety enhancement, cost reduction, parts-supply improvement, competitive levelling, or general benefit to the sport is identified.
- Permission for any proposed change **MUST** be applied for in writing to BriSCA F2 via the following channels:
  - Mail: [BriSCA F2, Nylands, Charlton Horethorne, Sherborne, Dorset, DT9 4NG](mailto:BriSCAF2@nylands.com)
  - Web: Use the online contact form at [www.BriSCAf2.com](http://www.BriSCAf2.com)
  - Email: [BriSCAF2tech@outlook.com](mailto:BriSCAF2tech@outlook.com) (All changes except Zetec engines)
  - Email: [Zetec@BriSCAF2.com](mailto:Zetec@BriSCAF2.com) (Zetec engine changes only)
- Proposed changes will be considered by the BriSCA F2 Technical Committee and an official response duly made as appropriate.
- Drivers must NOT fit unapproved parts or components, or make modifications, that do not meet the current technical specifications, whether they believe they have a case for them or not. A process for approval exists and should be followed by all drivers.

## 200 General Regulations

### 200.01 Spirit of the Regulations

**200.01.01** Any design, component, modification, or action taken, as permitted or required, must be carried out within the spirit of these regulations, namely...

- Safety
- Fair and level competition
- Control of cost
- Limited technical development
- General component availability
- Safeguarding the future of the sport

**200.01.02** BriSCA F2 and its Officials reserve the right to require the removal, replacement, or modification of any part of the car, or component, which is deemed not to be within the spirit of these regulations, within an appropriate time-frame.

### 200.02 Technical Regulations

**200.02.01** The drilling, lightening or other modification of any plates, bars or safety components is NOT permitted unless explicitly stated in these regulations.

**200.02.02** Standard parts must NOT be changed or altered unless explicit permission is given in these regulations.

**200.02.03** The use of ceramic bearings is NOT permitted anywhere on the car.

**200.02.04** Unless a regulation explicitly states an action can be taken, a modification made, or a replacement part sourced/manufactured, then such actions/modifications/replacements are NOT permitted. This is the overriding principle for ALL technical regulations.

**200.02.05** Unless these published regulations explicitly state something can be implemented, then it CANNOT.

**200.02.06** Prior approval MUST be sought and received for any changes to the current published regulations or to allow the use of any non-standard or modified parts. Requests MUST be submitted to BriSCA F2 and will be considered for the following year's regulations. Such parts or changes must NOT be implemented until approval has been granted as appropriate.

**200.02.07** The deliberate tampering with, or modification of safety components, e.g. safety harnesses, and one-way fuel safety valves, in contravention of the regulations below and/or the component's intended design purpose, WILL lead to disciplinary proceedings which may result in disqualification, a fine, and/or a racing ban dependent on the circumstances.

**200.02.08** Tolerances, where specified, are included to allow for manufacturing/installation variations and/or in-race damage. They are NOT a starting point for set-up, nor do they permit the machining of components where not expressly stated.

### 200.03 Illegal Components

**200.03.01** A meeting promoter or senior BriSCA F2 Official retains the right to confiscate or impound any item(s)/component(s) that do not conform to these regulations.

### 200.04 Safety

**200.04.01** **General** – Any driver safety equipment presented for a safety check (e.g. helmet, gloves, balaclava, or a race-suit), that does not conform to the current regulations, or is determined to be unsafe (e.g. gloves with holes in them) may be retained during the meeting by the scrutineer, promoter or appointed official.

**200.04.02** **Helmets** – Any helmet presented for a safety check that does not conform to the current standards will be labelled with an ORCi “Failed” sticker and only returned to the driver at the end of the meeting.

**200.04.03** **Gloves** – Any gloves presented for a safety check, which are deemed beyond repair, will be retained by the promoter, senior BriSCA F2 official, or their appointed representative.

**200.04.04** **Gloves** – Any gloves that fail a safety check, but that are deemed repairable, will be returned to the driver at the end of the meeting.

**200.04.05** **Fluid Leaks** – A meeting promoter, senior BriSCA F2 Official, or their appointed representative, retains the right to disqualify a car during a race, or prevent a car from racing, due to excessive fluid leaks that may adversely impact competitors and/or track conditions, e.g. axle fluid leaking from a half-shaft seal.

### 200.05 Car and Engine Components

**200.05.01** The meeting promoter or a senior BriSCA F2 official will retain any component suspected of being illegal (E.g. an underweight flywheel, or an illegally modified engine component). The driver will be subject to a technical investigation/disciplinary process as appropriate.

**200.05.02** In the case of engines, only the suspected component will generally be retained, however, should the allegation be sufficiently serious (e.g. the crank, rods and pistons), then the entire engine may be retained during the investigation/disciplinary process.

**200.05.03** Any retained component deemed to be legal and within the regulations will be returned to the driver at the conclusion of any investigative/disciplinary process.

**200.05.04** BriSCA F2 will retain any component deemed illegal to the current regulations.

## **200.06 Performance Monitoring/Alteration**

**200.06.01** The installation and/or use of any kind of system(s) or components to facilitate the logging, and/or transmission of engine or chassis data/information/operating-parameters is NOT permitted unless explicitly stated elsewhere in these regulations. This includes, but is not limited to, fittings, wiring, outlets, data loggers, or any other kind of hardware/software.

**200.06.02** The installation and/or use of any kind of system(s) to automatically alter the engine, or car performance, e.g. lambda sensors, is NOT permitted unless explicitly stated elsewhere in these regulations.

**200.06.03** The use of telemetry devices to wirelessly transmit information is NOT permitted.

## **200.07 Actions Affecting Car Legality**

**200.07.01** Any deliberate action taken by a driver or team-member on track, during or after a race, that affects the ability of any official to check the legality of the car or any of its components as raced, or attempts to conceal any illegality, will potentially result in disqualification. This includes, but is not limited to, (i) deliberately impacting an object such as the fence, a marker tyre, or another car to deliberately damage a component, (ii) altering adjustable component settings during post-race celebrations, (iii) adding or removing anything to/from the car.

## **201 BriSCA Formula 2 Stock Car Definition**

**201.01** A BriSCA Formula Two Stock Car (referred to as the car in these regulations) MUST be:

- Open-wheel in design and construction around a basic steel ladder chassis under which a tubular space-frame undercarriage (lower-chassis) is constructed, and on top of which a roll-cage is mounted.
- Front-engined
- Rear-wheel drive
- A single seater car

**201.02** The main centreline of the car is defined as a line running along the horizontal length of the car, equidistant between the two main chassis rails when viewed from above.

**201.03** The engine, gearbox, and driver's seat, MUST all be fitted along the main centreline of the car within the tolerances quoted in the individual regulations below.

**201.04** The front and rear axles MUST be fitted centrally in the car, relative to the car's centreline, within the tolerances quoted in the individual regulations below.

## **202 Weight and Ballast**

### **202.01 Weight**

**202.01.01** The MINIMUM permissible total weight of the car is 660Kg.

**202.01.02** The MAXIMUM permissible total weight of the car is 725Kg.

**202.01.03** The MAXIMUM permissible inside (left side) weight distribution is 52.50%.

**202.01.04** Cars may be weighed at ANY time before, during, or after a meeting and MUST comply with the weight regulations at ALL times.

**202.01.05** ALL weighing measurements are taken WITHOUT the driver in the car.

**202.01.06** At ALL tracks, the adding of fluids, or making of changes of any kind to the car to bring it within limits for a post-race weight check is NOT permitted.

**202.01.07** At shale tracks ONLY, excess shale may be removed from the car under supervision, and the car subsequently re-weighed if it is found to be outside the legal limits on first weighing after a race.

**202.01.08** Cars may be modified in order to pass any pre-meeting weight checks WITHOUT penalty.

**202.01.09** The penalties for inside (left-side) weight infringements are detailed in the Technical Infringement Penalties section of these regulations.

### **202.02 Ballast**

**202.02.01** Bolt-on ballast is NOT permitted.

**202.02.02** The use of any solid steel bars and/or plate over 3mm in thickness in the construction of the chassis, bumpers, nerf-rails, or component parts, that may be construed as ballast, is NOT permitted. This includes, but is not limited to, radiator mounting frames, fuel-tank strapping, and gusseting.

- 202.02.03** The use of solid steel bar and/or plate, exceeding the maximum 3mm permitted thickness stated above, is explicitly permitted for the following purposes:
- Mounting steering components
  - Mounting suspension components, including leaf-springs
  - Mounting bolt-on bumpers
  - Mounting wheel-guards
  - Mounting brake master-cylinders
  - Front uprights / stub-axles
  - Engine mounts
  - Seat mounts, protection plate and headrest plate
  - Prop-shaft hoops
  - Roof plate and wing mounts
  - Nerf-rail to chassis mounting sacrifice plates (to prevent chassis leg damage when cutting off / welding-on nerf-rails)
- 202.02.04** The lamination of steel plates in the construction of ANY part of the car, or the installation/construction of multiple steel plates in close proximity to each other which can be construed as ballast, is NOT permitted.
- 202.02.05** Tubular bars or box section must NOT be filled with ANYTHING that will increase their weight.
- 202.02.06** The adjacent placement of three or more lengths of tube (e.g. RHS, SHS, CHS), in parallel and any orientation, thus forming a wall or stack, is NOT permitted, except where explicitly required, e.g. in the construction of nerf-rail and bumper blades. Where three or more lengths of tube are used in parallel to construct part of the chassis, e.g. a protective side-pod wall, then a MINIMUM gap between each tube, equal to twice the larger width/diameter of the tube MUST be maintained. E.g. a 50mm gap must be maintained between multiple lengths of 25mm CHS, or 100mm between multiple lengths of 25x50mm RHS.

## 203 Chassis Construction

### 203.01 General

- 203.01.01** The car MUST have a steel chassis and roll-cage of welded construction.
- 203.01.02** Brazing is NOT permitted on the chassis or roll-cage.
- 203.01.03** All joints of the chassis rails, cross-members, undercarriage, and roll-cage MUST be fully welded.
- 203.01.04** The chassis cab floor, main rails, bumpers, nerf-rails, and roof-plate MUST ALL be in the same horizontal plane when the chassis is placed on a level surface and viewed from the front and rear.

### 203.02 Main Chassis Design

- 203.02.01** The chassis must be constructed with two separate main chassis rails running longitudinally from the front to the rear of the car.
- 203.02.02** The chassis rails MUST measure at least a MINIMUM of 450mm apart at all points along their length.
- 203.02.03** The main chassis rails MUST start/terminate forward of the line of the front axle, and rearward of the rotational centre of the rear axle.
- 203.02.04** The main chassis rails may be constructed in a traditional flat ladder-chassis type design, or alternatively they are permitted to rise and fall up to a MAXIMUM of 100mm over their length if a triangulated or non-flat design is preferred.
- 203.02.05** A MAXIMUM of two bends in each chassis rail in the horizontal plane, and a MAXIMUM of two bends in each chassis rail in the vertical plane, along their length are permitted. Example uses for such bends include a raised main rail, or a wider driver's cab area.
- 203.02.06** Both main chassis rails MUST be installed in the same symmetrical orientation when viewed from the front/rear. E.g. Both with edges parallel/perpendicular to the ground, or with edges at 45° to the ground.
- 203.02.07** The centreline of the chassis MUST be perpendicular to the front and rear bumpers, with the main rails equidistant from it at all points along its length.
- 203.02.08** The main chassis rails MUST be joined to each other at the rear by a transverse cross-member. This cross-member will form one of the sides to which the rear-plate MUST be welded (see below).
- 203.02.09** The vertical centre at all points along the entire length of the main chassis rails, and across any transverse cross-members joining them together, MUST be level with or above the centreline of the bumpers when viewed from the side.

### 203.03 Main Chassis Materials

- 203.03.01** The main chassis rails and rear cross-member **MUST** be constructed of RHS or SHS with at least a **MINIMUM** size of 40mm x 40mm, and at most a **MAXIMUM** size of 70mm x 70mm.
- 203.03.02** The main chassis rails and rear cross-member **MUST** be constructed of RHS or SHS with a **MINIMUM** wall thickness of at least 3mm.

### 203.04 Undercarriage/Lower-Chassis

- 203.04.01** An undercarriage/lower chassis in a tubular space-frame design may be constructed underneath the main chassis rails for the purpose of mounting suspension components, installing floor sections, mounting the engine and transmission, and/or protecting the driver.
- 203.04.02** The undercarriage/lower-chassis **MUST** be constructed from steel hollow section (CHS, SHS, RHS or OHS), and be fully welded to the main chassis rails. The construction of the undercarriage/lower chassis from steel plate is not permitted.
- 203.04.03** Any lower chassis rails/undercarriage must **NOT** extend beyond the footprint of the main chassis rails and their cross-members when viewed from above.
- 203.04.04** The distance between the main chassis rails and the undercarriage/lower chassis rails **MUST** be equal on **BOTH** sides of the car.
- 203.04.05** The undercarriage/lower-chassis **MUST** be symmetrical about the centre-line of the car when viewed from the front and rear.
- 203.04.06** Additional metal panel-work, where required, e.g. to form a firewall, or prevent the ingress of shale/water, is permitted.

### 203.05 Roll-Cage

Refer to [Technical Diagram 01](#) for a pictorial representation of the required material specifications.

#### Primary 7-Pillar Roll-Cage Structure Design

- 203.05.01** The car **MUST** have an integral 7-pillar roll-cage, welded on top of the main chassis rails, to protect the driver.
- 203.05.02** ALL joints of the roll-cage structure, and any other integral components connected to it, e.g. seat mounting bars (see below), **MUST** be fully welded.
- 203.05.03** The roll-cage **MUST** be constructed from two main hoops running up from the main chassis rails, over the height of the driver's head & helmet, and back down to the chassis rails again. The two main hoops **MUST** run either (i) front to back along the line of the main chassis rails, or (ii) side to side between the two chassis rails, thus forming the 4 corner pillars (pillars 1-4) of the required 7-pillar roll cage.
- 203.05.04** The two main roll-cage hoops **MUST** be connected to each other at the top by two roof bars:
- One front and one rear running transversely in the case of front-to-back main hoops, OR
  - One at each side running longitudinally in the case of side-to-side main hoops.
- 203.05.05** Two additional side pillars (pillars 5 & 6) **MUST** also directly connect the main chassis rails to the roll hoop(s) above the driver's head (one pillar on each side of the car between the front and rear pillars) forming a continuous structure. These pillars **MUST** be welded directly to the main chassis rails at the bottom, and the roll hoops at the top, and **NOT** rely on any other component as part of their construction, e.g. a suspension mount.
- 203.05.06** The top and bottom sections of the middle pillars must **NOT** be offset from each other where they intersect any side or other protection bars (see below).
- 203.05.07** One additional rear pillar (pillar 7) **MUST** directly connect the centre of the rear transverse roof bar/roll-hoop (that joins the two rear roll-cage corner pillars together at the top of the rear window aperture) to the centre of the rear roll-cage lower transverse cross member (that joins the two rear corner roll-cage pillars together at the base of the rear window aperture – see below). This lower cross-member, to which the 7th pillar is connected, is the same cross-member to which the rear steel plate must be welded. Refer to [Technical Diagram 01](#), in which this cross-member is coloured green.
- 203.05.08** The 7<sup>th</sup> pillar **MUST** be vertical when viewed from the front or rear of the car, **MUST** be installed mid way between the left and right rear corner pillars of the roll-cage, and **MUST** be constructed using a single length of material. There is no mandatory requirement for this pillar to extend all the way down to the main chassis; however, it may be installed in this way if a driver/constructor so desires (subject to roll-cage plating regulations – see below).
- 203.05.09** When viewed from the side, the 7<sup>th</sup> pillar **MUST** follow the same profile as the two rear corner pillars, such that it sits inside of, or level with, a straight-edge butted up against them at any point along their length. Where the centre of the roof and/or rear-window cross-member(s) protrude beyond the profile of the two rear corner pillars, e.g. a curved-out rear-window cross-member, or curved up/out rear roof bar, a **MAXIMUM** distance of 75mm from the rearmost

edge of the 7<sup>th</sup> pillar's side-profile to the rearmost edge of the corner pillars' side-profile is permitted.

- 203.05.10** In order to ensure compliance with the above specification, a flat bar, MINIMUM 2mm in thickness (e.g. a steel or aluminium rule) MUST be able to pass straight through the cab/roll-cage structure, under the level of the roll-cage hoops, and above the driver's helmet (when the driver is strapped in the car in the normal racing position), without bending/deflection, thus demonstrating that the roll-cage hoops do indeed run over the height of the driver's head/helmet.

#### Technical Diagram 01

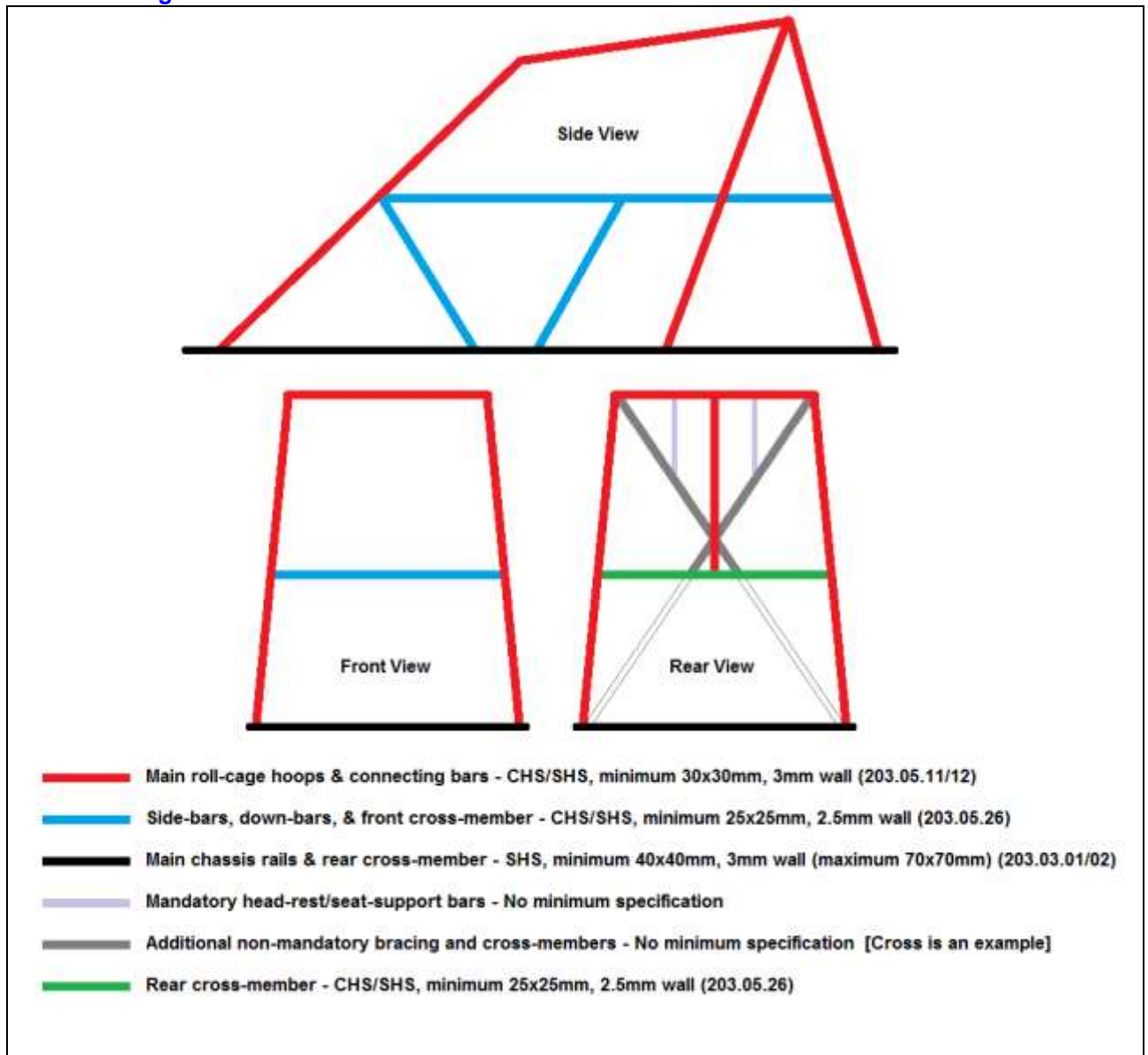

#### Primary 7-Pillar Roll-Cage Structure Materials

- 203.05.11** The main hoops (pillars 1-4), their connecting bars (regulation 203.5.4), and additional pillars (5, 6 & 7) MUST be constructed of SHS or CHS with a MINIMUM wall thickness of 3mm.
- 203.05.12** The main hoops (pillars 1-4), their connecting bars (regulation 203.5.4), and additional pillars (5, 6 & 7) MUST be at least a MINIMUM size of 30mm x 30mm (SHS), or 30mm diameter (CHS).

#### Additional Roll-Cage Structure Design

##### Side-Bars

- 203.05.13** Side-bars running longitudinally between the front and rear roll-cage pillars MUST be installed on both sides of the car at approximately elbow height.

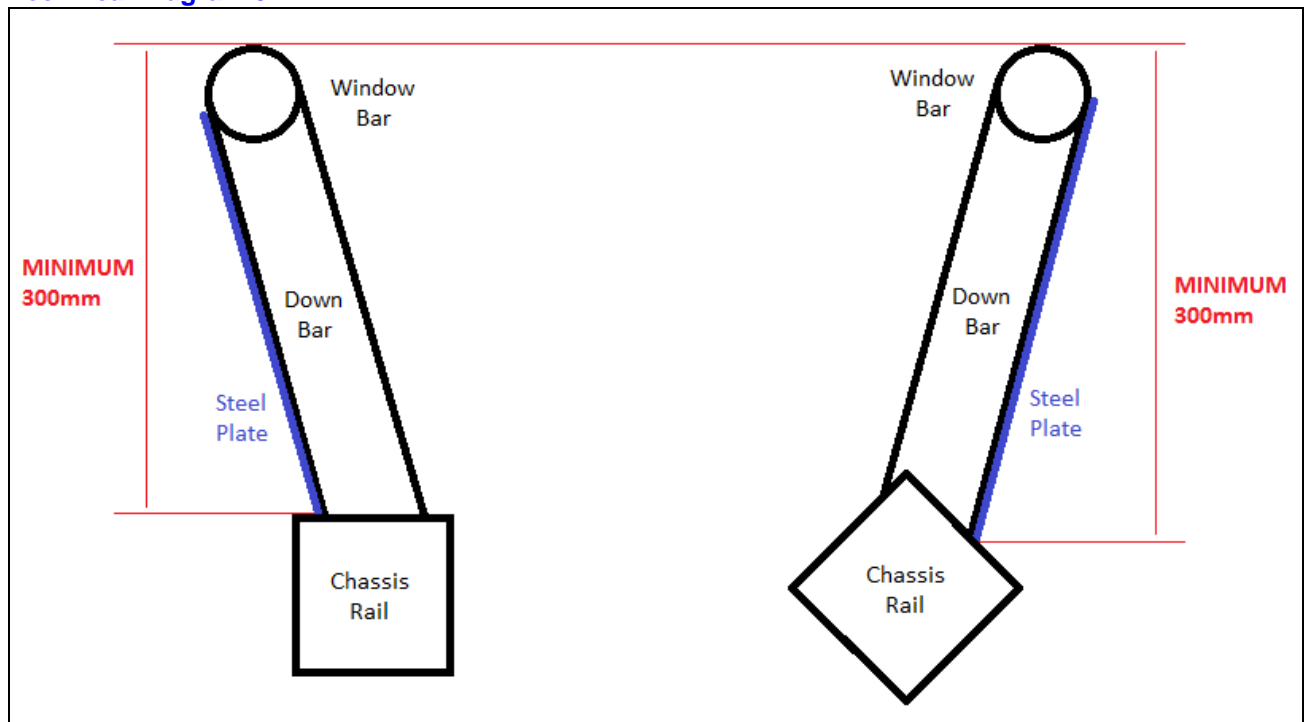

- 203.05.14** The side-bars MUST abut, or be abutted by, the middle roll-cage pillars on each side of the car, and all joints to the roll-cage pillars MUST be fully welded.
- 203.05.15** The side-bars MUST be equal heights from the chassis rails on both sides of the car.
- 203.05.16** At all points along their length, the side-bars MUST measure at least a MINIMUM height of 300mm vertically from the top of the bar (excluding bodywork panels) to the point at which the steel side-plates (see below) are welded to the main chassis rails.
- In the case of cars with a “diamond chassis” type design, the measurement will be taken vertically from the top of the side-bar (excluding bodywork panels) to the point at which the vertical would intersect with a flat main chassis rail were the car to have been constructed with a traditional flat ladder-chassis type design. Cars employing the “diamond chassis” type design will already be carrying larger foot protection side-plates than cars with a traditional flat ladder-chassis, and therefore this method of measurement will ensure competitive parity of plating weights.
- See [Technical Diagram 02](#) for a visual guide to the method of window bar height measurement.
- 203.05.17** It is NOT permitted to roll the mandated steel side plates (see below) up and over the side-bars in order to gain additional height in cars where the side-bars are currently installed too low down to conform to these regulations.
- 203.05.18** The side-bars MUST measure at least a MINIMUM of 750mm apart from inside edge to inside edge at the driver’s seat.

**Technical Diagram 02****Down-Bars**

- 203.05.19** At least two separate down-bars MUST be installed on each side of the car within the area bordered by the front and middle roll-cage pillars, the main chassis rail and the side-bar, primarily designed to provide protection for the driver from intrusion in to the cab area from bumpers (through the side panel). At least 1 down-bar MUST connect the side-bar to the main chassis rail, whilst a second down-bar MUST connect either the side-bar or the front roll-cage pillar to the main chassis rail.
- 203.05.20** The down-bars MUST be welded at both ends (to the chassis rails and side-bars/roll-cage pillars), and be equally spaced (as far as practically possible, and with the safety of the driver in mind) so as to divide the area (between the front and middle roll-cage pillars, main chassis rails, and side-bars) in to equal size apertures.
- 203.05.21** The use of non-vertical down-bars is permitted to allow triangulation for improved strength, subject to the regulations above.

- 203.05.22** The middle roll-cage pillar on each side of the car (pillars 5 & 6) does NOT count as one of the two down-bars, which MUST be in addition to the 3 roll-cage pillars mandated on each side of the car (see above).

#### **Cross-Members**

- 203.05.23** The rear roll-cage pillar on both sides of the chassis MUST be joined to the other by a transverse horizontal cross-member. This cross-member will form one of the sides to which the rear plate MUST be welded (see below), and the base to which the 7<sup>th</sup> pillar (see above) MUST be welded.
- 203.05.24** The front roll-cage pillar on both sides of the chassis MUST be joined to the other by a transverse horizontal cross-member at the base of the windscreen aperture at approximately elbow height.
- 203.05.25** The joints of the front and rear cross-members to the respective roll-cage pillars MUST be fully welded, thus completing an integral structural ring around the roll-cage/driver at approximately elbow height.

#### **Additional Roll-Cage Structure Materials (Side/Down-Bars, Cross-members)**

- 203.05.26** With the exception of the 7 main roll-cage pillars and two roof bars as specified earlier (203.5.1-10), all other parts of the roll-cage specified above (203.5.13 onwards) MUST be constructed of SHS or CHS with a MINIMUM wall thickness of 2.5mm, and at least a MINIMUM size of 25mm x 25mm (SHS) or 25mm diameter (CHS).

#### **203.06 Roll-Cage Plating – Roof**

- 203.06.01** A single steel sheet plate of MINIMUM 3mm thickness MUST be welded to the top of the roll-cage along the full length of all 4 sides (the two main roll-cage hoops and the two connecting bars) to form a protective roof plate over the driver's head.
- 203.06.02** The roof plate MUST measure at least a MINIMUM of 560mm in length across its entire width, and at least a MINIMUM of 400mm in width along the mandated MINIMUM 560mm length. These dimensions include the diameter of the roll-cage tube to which the plate is welded.
- The 400mm width measurement is taken in the transverse horizontal plane, parallel to the ground, between two vertical straightedges butting against the outsides of the roll-cage tube.
  - The 560mm length measurement is taken parallel to the longitudinal plane of the roof, between two straightedges perpendicular to the front and rear of the roof.
- 203.06.03** The use of a non-rectangular roof plate is permitted, if so designed, but it must conform to the above specification, i.e. be a MINIMUM of 560mm in length at all points, not just the centre, and a MINIMUM of 400mm in width for the MINIMUM 560mm mandated length.
- 203.06.04** The welding together of multiple sections of plate to form a roof plate is NOT permitted.
- 203.06.05** The roof plate must NOT be drilled or lightened in any way, except for the fitting of a roof fin or superstar lights.
- 203.06.06** There MUST be a clearance between the driver's helmet and the roof plate (in addition to the roll-cage clearance detailed above), such that the helmet cannot strike the roof during an impact when the driver is strapped in the racing position. (The human neck and body have a natural tendency to move and stretch during a violent impact, while safety harnesses are designed with a degree of stretch capability in order to potentially reduce injury).

#### **203.07 Roll-Cage Plating – Rear**

- 203.07.01** The rear of the roll-cage MUST be panelled with a steel sheet plate of at least 2mm MINIMUM thickness, and to a MINIMUM height of at least 300mm above the level of the main chassis rails along its entire length.
- 203.07.02** The rear plate MUST be FULLY welded along all sides (to the two roll-cage pillars, the chassis cross-member, and the mandated roll-cage cross-member to which the 7<sup>th</sup> pillar is also welded).
- 203.07.03** The rear plate must NOT be drilled or lightened in any way.

#### **203.08 Roll-cage Plating – Sides**

- 203.08.01** Both sides of the roll-cage MUST be panelled with steel sheet plate of at least a MINIMUM thickness of 2mm, to fully enclose the area bordered by (i) the main chassis rail, (ii) the rear roll-cage pillar, (iii) the side window bar, and (iv) the front roll-cage pillar, or a vertical down-bar linking the chassis rail to either the window bar or front roll-cage pillar.
- 203.08.02** The plate may be fitted as either a single piece (formed as required), or up to a MAXIMUM of 4 pieces on each side of the car (for easier fitment on non-flat cab sides). A single piece of plate is permitted to cover multiple apertures, but multiple plates must NOT be joined to each other to cover a single aperture. [This is illustrated in Technical Diagram 03.](#)

- 203.08.03** The plate **MUST** be fitted to the outside of the roll-cage/window-bar/down-bars, or inset up to a **MAXIMUM** of 5mm from the outer edge of the roll-cage tubes.
- 203.08.04** Each section of plate **MUST** be fully welded to the roll-cage structure and chassis rail along the full length of each of its sides (in the same manner as the rear panel).
- 203.08.05** The solid covered side of the cab **MUST** measure at least a **MINIMUM** of 1,200mm in length from the rear of the rear roll-cage pillar at the point where it meets the chassis rail, horizontally, to the vertical plane at the front of the foremost tube/post to which the plate is welded. [This is illustrated in Technical Diagram 03.](#)
- 203.08.06** Where the side plate terminates behind the point at which the front roll-cage pillar meets the chassis rail, then the foremost edge of the side-plate and the bar to which it is welded must be vertical or angled forward from the chassis rail up to the window-bar or roll-cage pillar.
- 203.08.07** Where the distance from the front to rear roll-cage pillars is less than the mandated minimum 1,200mm covered length, an additional steel bar **MUST** be welded around the exposed front and upper edges of the mandated steel plate, connecting the chassis rail to the front roll-cage pillar at the point where the side-bar meets it.
- 203.08.08** The height of the side-plates is determined by the height of the side-bars (to which it **MUST** be welded) detailed separately in these regulations.
- 203.08.09** Cutting the side plates around rear shock-absorber or rocker mounting brackets is permitted. Side plates do not need to be welded to any such brackets, and a **MAXIMUM** clearance of 15mm between a bracket and the plate is permitted. Where shock-absorber rockers are installed for in-board suspension then the 15mm measurement is taken with the rocker at its maximum travel.
- 203.08.10** Cutting a hole in each side plate to allow the fitment of a rear anti-roll bar is permitted. The **MAXIMUM** permitted size of each hole is 75mm diameter / 75mm square.

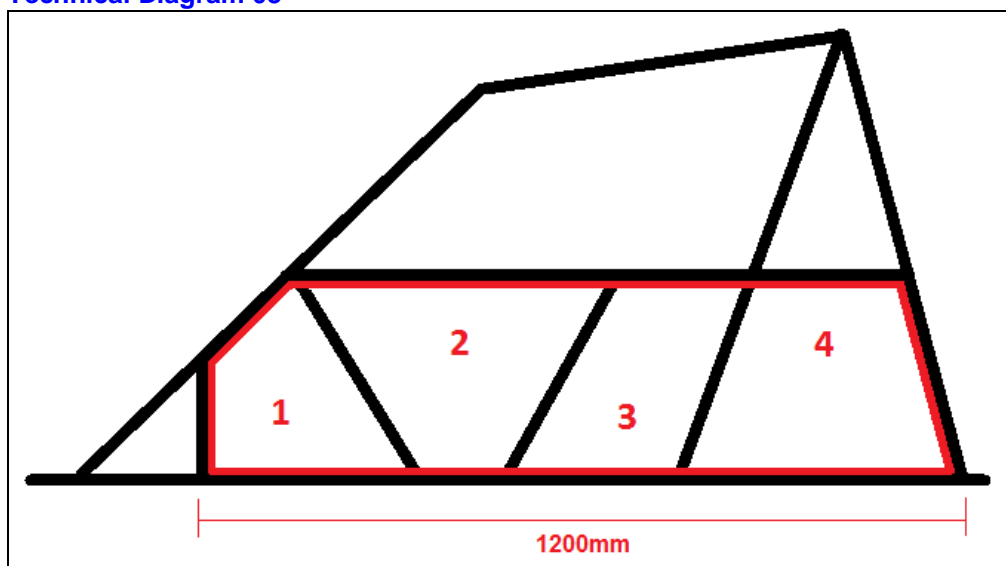
**Technical Diagram 03****203.09 Bodywork****General**

- 203.09.01** ALL panels/body-work, where fitted, **MUST** be constructed of metal, unless specified below. The use of fibreglass, carbon-fibre, Kevlar, or other material(s) is **NOT** permitted.

**Roll-Cage**

- 203.09.02** The roll-cage **MUST** be enclosed with metal panel-work, up to the level of the side-bars, on both sides of the car, and the rear.
- 203.09.03** The area between the middle and rear roll-cage pillars, above the side-bar may be panelled if so desired, but any panel **MUST** be metal if fitted.
- 203.09.04** Equal apertures **MUST** be left on **BOTH** sides of the roll-cage for driver entry/exit.
- 203.09.05** A rear “window” **MUST** be left open to allow access for scrutineering checks.

**Engine Cover**

- 203.09.06** The engine cover is defined as the primary single removable section of body-work/panelling enclosing the top of the engine.

- 203.09.07** The use of metal, Kevlar, and/or fibreglass in the construction of the engine cover is permitted. The use of carbon-fibre is NOT permitted.
- 203.09.08** The engine compartment MUST be FULLY enclosed above the main chassis rails by the engine cover and any additional panel-work as necessary. The cover and any additional panel-work MUST be securely fitted.
- 203.09.09** The use of open ventilation holes cut in the cover, side panels, and/or top panelling covering the engine (above the main chassis rails), and/or enlarged holes around the exhaust/inlet manifolds, is NOT permitted.
- 203.09.10** The use of ventilation holes at the rear sides of the engine cover, above the main chassis rails ONLY, to allow sufficient air-flow through the engine compartment to provide adequate engine cooling, especially on shale, is permitted. The side of the engine cover MUST overlap with the cab side-panel behind it by at least a MINIMUM of 50mm at the point of the ventilation opening.
- 203.09.11** A front grille in the engine cover design, to allow cooling airflow to the radiator/engine, is permitted.

#### **203.10 Windscreen**

- 203.10.01** The windscreen aperture(s) must be covered with a steel mesh to protect the driver from projectiles.
- 203.10.02** The steel mesh MUST be no more than a MAXIMUM 40mm matrix, and MUST be a MINIMUM 2.4mm thickness.
- 203.10.03** The steel mesh MUST be securely fitted to the car by welding, or through the use of a MINIMUM of 4 metal fixings (1 per corner) including, but not limited to, nuts and bolts, “U”-bolts, or “Jubilee” clamps. The use of cable-ties, whether metal or plastic, is NOT permitted.
- 203.10.04** It is NOT permitted to drill holes in ANY roll-cage tube/bar for the purpose of mounting the steel mesh.
- 203.10.05** An additional solid screen may be fitted if required (e.g. for racing in the rain or on shale), but it MUST be made of a material that will not shatter if impacted.
- 203.10.06** The steering wheel MUST be positioned well inside the cab, such that the driver’s fingers are not at risk of catching in the windscreen mesh under normal racing conditions.

#### **203.11 Mud-Guards/Wheel-Arches**

##### **Front Wheels**

- 203.11.01** Mud-guards/wheel-arches are NOT permitted over/around the front wheels of the car.
- 203.11.02** Attachment of a mud-guard/splash-guard to the front part of the nerf-rail(s), to protect the driver from water/shale being flicked up from the front tyre(s), is permitted. Any such device MUST be securely attached, and must NOT extend any further forward than the rear-most point of the tyre (with the wheels facing straight forward).

##### **Rear Wheels**

- 203.11.03** Integral “retro-style” mud-guards/wheel-arches over the rear wheels are permitted, if desired, but they must NOT cover any more than one-quarter of the wheel when viewed from the side in order to maintain the spirit of an open-wheel stock car.
- 203.11.04** If fitted, a rear wheel mud-guard/wheel-arch MUST be present on BOTH sides of the car, and they MUST be symmetrical in design/appearance.
- 203.11.05** Any mud-guard/wheel-arch must NOT extend below the level of the main chassis rail.
- 203.11.06** Any mud-guard/wheel-arch must NOT extend rearwards beyond the vertical plane through the rotational centre of the wheel.
- 203.11.07** Any mud-guard/wheel-arch must NOT extend outwards from the chassis rail beyond the outer edge of normal dry-running wheels.
- 203.11.08** Any mud-guard/wheel-arch must NOT extend outwards from the chassis rail beyond the outer edge of the nerf-rail (excluding any wheel-guards).

## **204 Bumpers**

### **General Requirements**

- 204.01** The lightening of any mandated specification material in the construction of the bumpers, bracing, brackets, mounts, and mandatory hoops is NOT permitted.
- 204.02** The ends of ALL hollow section material used in the construction of bumpers, bumper-hoops, wheel-guards and mountings, around the perimeter of the chassis, MUST be capped with a fully-welded, closed, steel cap. The use of “penny” washers on circular tube is permitted, but any hole in the washer MUST be welded closed.

### **Construction Specification**

- 204.03** The car MUST be fitted with front and rear bumpers constructed of steel.

**204.04 Front Bumper**

**204.04.01** The front bumper blade **MUST** be constructed with a flat face surface 100mm (4in) deep along its entire length.

**204.04.02** The top and bottom edges of the front bumper **MUST** remain in the same parallel horizontal plane at all points along the entire length. The dropping of bumper ends is not permitted.

**204.05 Rear Bumper**

**204.05.01** The rear bumper blade **MUST** be constructed with a flat face surface 100mm (4in) deep along its entire length, except as noted below.

**204.05.02** The top and bottom edges of the rear bumper **MUST** remain in the same parallel horizontal plane at all points along its entire length, except as noted below. The dropping of bumper ends is **NOT** permitted. [This is illustrated in Technical Diagram 04.](#)

**204.05.03** **ONLY** where a wheel-guard is installed, and **ONLY** for the purpose of mounting the wheel-guard and/or its brackets, a **MAXIMUM** of 100mm from the end of the bumper face is permitted to be deeper than the 100mm (4in) mandated above through the addition of material underneath the bumper. The **MAXIMUM** permitted depth of the bumper face in this area is 152mm (6in). This measurement is taken in the vertical plane. [This is illustrated in Technical Diagram 04.](#)

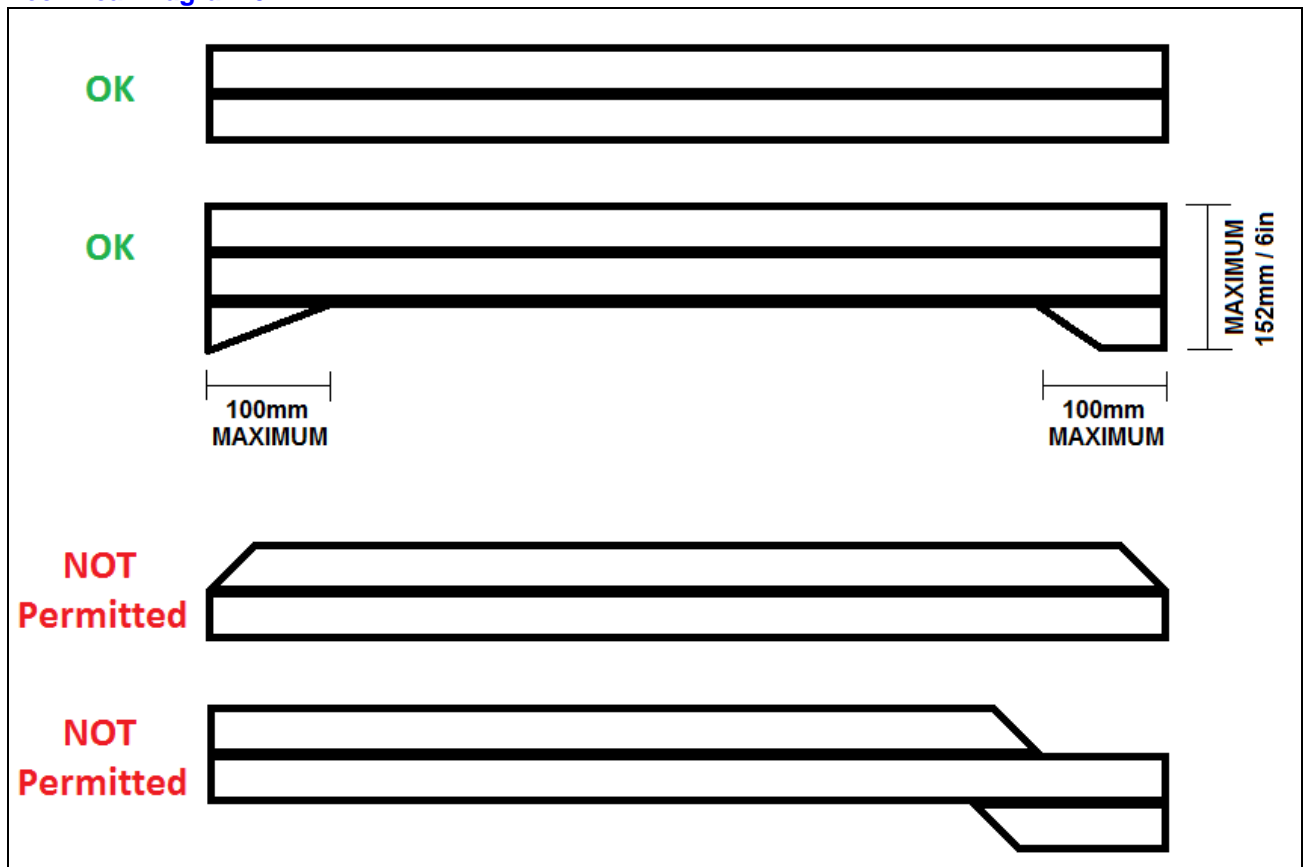
**Technical Diagram 04**

**204.06** Nipping off one or more corners of either bumper is **NOT** permitted. [This is illustrated in Technical Diagram 04.](#)

**204.07** The front and rear bumper blades **MUST** be constructed from material with a **MINIMUM** wall thickness of 2.5mm.

**204.08** The **MAXIMUM** permitted bumper blade thickness is 30mm ( $1\frac{3}{16}$ in).

**204.09** The **MAXIMUM** permitted bumper blade width is 1,676mm (66in). The bumper width is defined as the bumper face, whether flat or angled towards the wheels, and includes any additional bumper hoop ironwork that can be construed as forming part of the face.

**204.10** Wheel-guard mount plates on the rear bumper may extend beyond the 1676mm (66in) **MAXIMUM** width; however they **MUST** be constructed so as to only protrude forward from the rear bumper and **NOT** create any additional face area to that permitted above.

**204.11** Bumpers are **NOT** permitted to protrude beyond the outside edge of the nerf-rails on either side of the car.

**204.12 Front Bumper Mounting** – A MINIMUM of four angled mounting bars/brackets MUST be fitted to connect the front bumper blade to the main chassis (via bolt-on brackets, or directly welded), with two on each side of the chassis. These mandated bars/brackets MUST be constructed from a MINIMUM material specification of 30mm SHS, 30mm CHS, or 25mm x 50mm RHS, all with a MINIMUM wall thickness of 2.5mm. Additional bracing/mounting bars are free. [This is illustrated in Technical Diagram 05.](#)

**Technical Diagram 05**

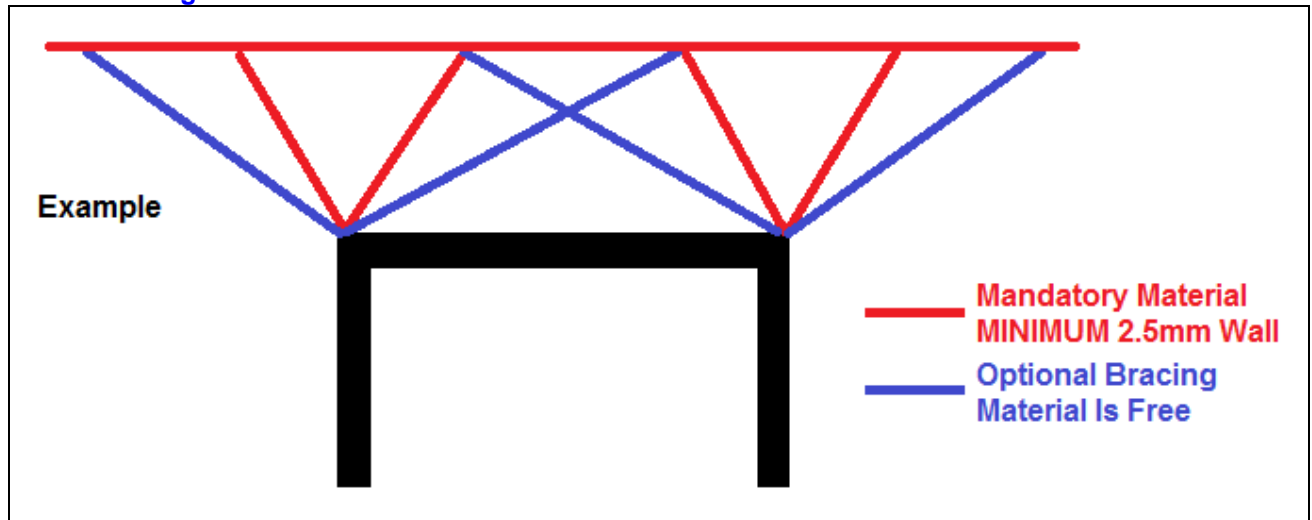

- 204.13 Rear Bumper Mounting** – The mounting brackets/bracing for the rear bumper blade are free in quantity and material specification.
- 204.14** The welding of additional transverse material, including, but not limited to SHS or RHS, to the inside of bumper blade faces (for strengthening or any other purpose) is NOT permitted.
- 204.15** A MINIMUM gap of 30mm MUST be maintained between the inner face of a bumper blade and any additional transverse bracing.
- 204.16 Outer Face Plating** – The use of small pieces of steel plate, welded to the outer face of a bumper blade, to effect repair or provide strengthening for bends is permitted, subject to the following:
- A MAXIMUM of 4 plates are permitted
  - The MAXIMUM permitted plate size is 100mm x 100mm.
  - The MAXIMUM permitted plate thickness is 5mm
  - It is NOT permitted to double-stack, overlap, or join plates together.
  - Plates are NOT included in the total overall thickness measurement (see above).
- 204.17 Inner Face Plating** – The use of small pieces of steel plate, welded to the inner face of a bumper blade, in to which the diagonal mounting brackets are run, or used to provide strengthening/support for diagonal bracing, is permitted, subject to the following:
- The MAXIMUM permitted plate size is 100mm x 100mm.
  - The MAXIMUM permitted plate thickness is 5mm
  - It is NOT permitted to double-stack, overlap, or join plates together.
  - Plate may ONLY be used where a brace runs in to the bumper blade.
  - Plates are NOT included in the total overall thickness measurement (see above).
- 204.18** Front AND rear bumpers MUST measure 410mm from the ground to the vertical centre of the bumper face, mid-way between the main chassis rails WITHOUT THE DRIVER in the car. This measurement MUST be within a tolerance of +/-10mm, i.e. up to a MAXIMUM of 10mm above or below the stated height.
- 204.19** Bumpers MUST be smooth on ALL extremities.
- 204.20** The front bumper MUST be 250mm or LESS from the front tyres in the horizontal plane. This measurement is taken horizontally from the rear of the bumper face at the point closest to the tyre (excluding any bracing or other constructional parts) to the point at which that horizontal plane intersects the tyre). [This is illustrated in Technical Diagram 06.](#)
- 204.21** The rear bumper MUST be 300mm or LESS from the rear tyres in the horizontal plane. This measurement is taken horizontally from the rear of the bumper face at the point closest to the tyre (excluding any bracing or other constructional parts) to the point at which that horizontal plane intersects the tyre). [This is illustrated in Technical Diagram 06.](#)



Technical Diagram 06

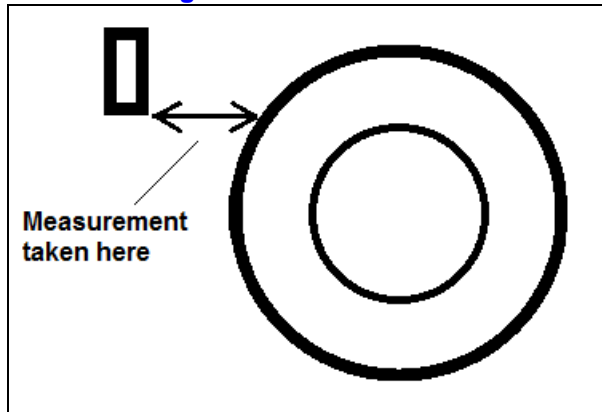

### Bolt-On Bumper Fixings

- 204.22** Bolt-on bumpers MUST be bolted to the chassis by a MINIMUM of four (in number), two on each side of the chassis, high-tensile bolts AND locking nuts with a MINIMUM bolt diameter of 12mm.
- 204.23** Bolt-on bumpers MUST have a MINIMUM of TWO secondary fixings to prevent the bumper leaving the car should the mounting bolts break in an impact.
- 204.23.01** Each secondary fixing MUST comprise of a steel chain made of MINIMUM 8mm thick diameter links, with ends joined together by a MINIMUM 8mm thick diameter steel shackle/link encompassing a threaded securing mechanism.
- 204.23.02** The threaded securing mechanism MUST be fastened tightly.
- 204.23.03** The use of locking-wire, or similar, to prevent the threaded securing mechanism from unscrewing, is permitted.
- 204.23.04** The use of nuts, bolts and washers to join the ends of the chain is NOT permitted.
- 204.23.05** Each secondary fixing chain MUST be wrapped around BOTH the chassis and suitable section of the bumper.

### Bumper Hoops

- 204.24** ALL bumper hoops, front and rear, and any mandated support/bracing for them, MUST be constructed from steel with a MINIMUM material specification of 25mm CHS/SHS, and a MINIMUM wall thickness of 2.5mm.
- 204.25** The front bumper MUST be fitted with a central lower hoop to help prevent the car riding up over other cars. This hoop MUST have a horizontal centre section a MINIMUM of 304mm (12in) wide, and be a MINIMUM of 152mm (6in) deep from the underside of the bumper along the entire horizontal section length. The bottom of this hoop MUST be braced to the rear by 2 support struts.
- 204.26** The front bumper MUST be fitted with a fence-side lower hoop to help prevent intrusion of the bumper end in to another car's driver's compartment. This hoop MUST be a MINIMUM of 102mm (4in) deep from the underside of the bumper, and smooth on all edges. The bottom of any tube used in the construction of this hoop MUST be capped with a fully welded, closed, steel cap. Sharp angles, or tapers, of less than 90 degrees that may cause tyre damage are NOT permitted on the bottom of the hoop.
- 204.27** The front bumper MUST be fitted with a fence-side upper hoop to help prevent intrusion of the bumper end in to another car's driver's compartment, and reduce the risk of entanglement with post and rope fences. This hoop MUST be a MINIMUM of 152mm (6in) and a MAXIMUM of 304mm (12in) high from the topside of the bumper, and smooth on all edges.
- 204.28** The installation of one or more hoops on the rear bumper, for the purpose of protecting the roll-cage and/or preventing another car from riding up and over the rear wheels, is optional.
- 204.29** The joining of front bumper hoops, or use of material to create additional hoops not mandated in these regulations, creating "saloon stock-car" style bumpers is NOT permitted. This includes, but is not limited to:
- Joining the central lower hoop to the right-hand, fence-end, lower hoop
  - Adding material joining the central lower hoop up to the left-hand, "infield" end, of the bumper flat
  - Adding other hoops above and/or below the main bumper blade/face
- 204.30** The use of a SINGLE bar to connect the top of the mandated front bumper, fence-end, upper hoop (on the right hand side of the car), over the right-front wheel, and back to the nerf-rail or main chassis rail on the right-hand side of the car IS permitted, but is optional.
- 204.31** The installation of any protection bars over or around the left-front wheel, and/or the rear wheels (with the exception of the mandated right-rear and optional left-rear wheel-guard – see below) is NOT permitted.
- 204.32** All mandatory bumper hoops are illustrated in Technical Diagram 07.

Technical Diagram 07

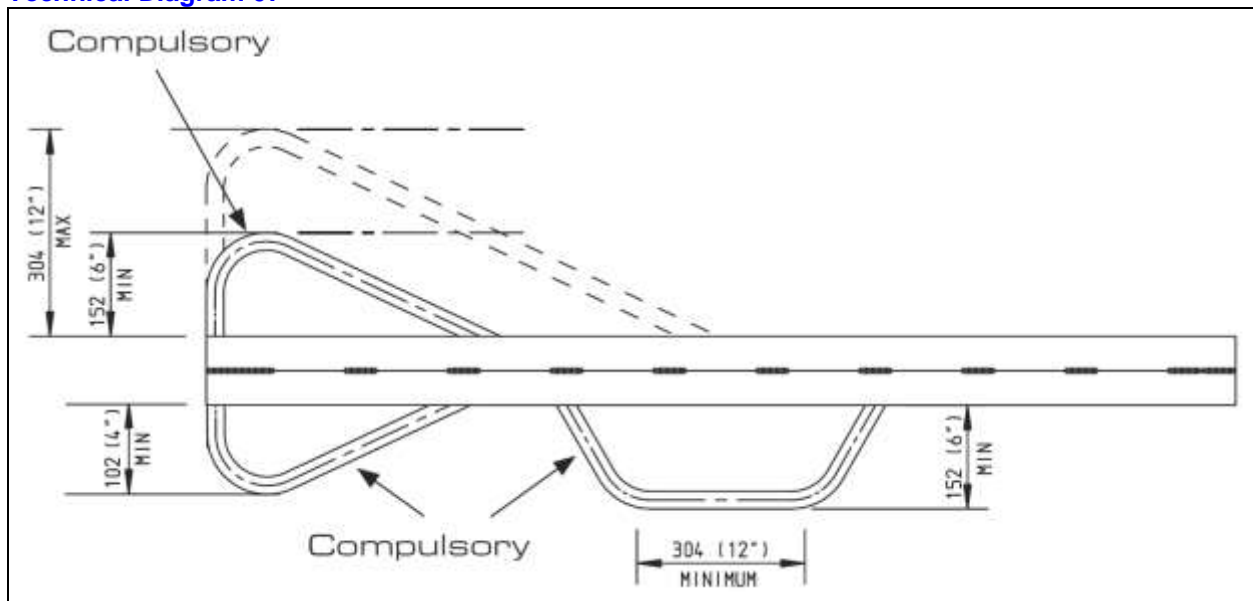

## 205 Nerf-Rails

### General Requirements

**205.01** Nerf-rails MUST be fitted to BOTH sides of the car and made of steel.

**205.02** The nerf-rails and their bracing MUST be symmetrical in appearance, both in design and external material dimensions, on BOTH sides of the car when viewed from above.

**205.03** The ends of ALL hollow section material used in the construction of the nerf-rails MUST be capped with a fully-welded, closed, steel cap.

**205.04** The lightening or drilling of any mandated specification material in the construction of the nerf-rails and their brackets/bracing, unless explicitly detailed below, is NOT permitted.

### Nerf-Rail Blades Construction Specification

**205.05** The nerf-rails MUST be constructed with an outer “blade” configuration similar in appearance to the front and rear bumpers.

**205.06** The nerf-rail outer blades MUST be constructed from a MINIMUM material specification of 50mm x 25mm RHS, or 30mm SHS, both with a MINIMUM wall thickness of 2.5mm. The use of CHS in the construction of nerf-rail blades is NOT permitted.

**205.07** Lengths of SHS/RHS must be welded together to form a vertical “blade” with a flat outer face. [Example configurations are illustrated in Technical Diagram 08.](#)

**205.08** Nerf-rail blades MUST be no smaller than a MINIMUM of 25mm in thickness, and 100mm in depth.

**205.09** Nerf-rail blades MUST be no larger than a MAXIMUM of 50mm in thickness, and 150mm in depth.

**205.10** Nerf-rail blades MUST run for a MINIMUM straight length of 1,100mm, front to rear, at the minimum 100mm depth or greater.

**205.10.01** Tapering the ends of the nerf-rail blades in depth is permitted, however any tapering below the minimum 100mm depth is not included as part of the minimum 1,100mm length specification. [This is illustrated in Technical Diagram 09.](#)

**205.10.02** Sharp pointed tapers are NOT permitted.

**205.10.03** Tapering the ends of the nerf rails in or out, e.g. to help prevent hooking up on fence-posts, is permitted, however any such tapered sections are not included as part of the minimum 1,100mm straight length requirement. [This is illustrated in Technical Diagram 09.](#)

### Nerf-Rail Blade Position

**205.11** The nerf-rail blades must run longitudinally, from front to rear, between the wheels, and parallel to the ground.

**205.12** The nerf-rail blades must be broadly in line with the bumper blades.

**205.13** The vertical centre of the nerf-rail blade MUST be level with, or lower, than the vertical centre of the main chassis rail.

**205.14** The top edge of the nerf-rail blade MUST be level with, or within 25mm below, the level of the top of the front and rear bumpers.

**205.15** Nerf-rails must NOT extend past the wheels (when the car is fitted with normal dry running wheels) on the axle with the widest track width by more than 2in (50mm) on each side of the car. This gives a MAXIMUM



total chassis width (excluding wheel-guards) of 72in (1828mm) if the MAXIMUM permitted track width is used.

**Technical Diagram 08**

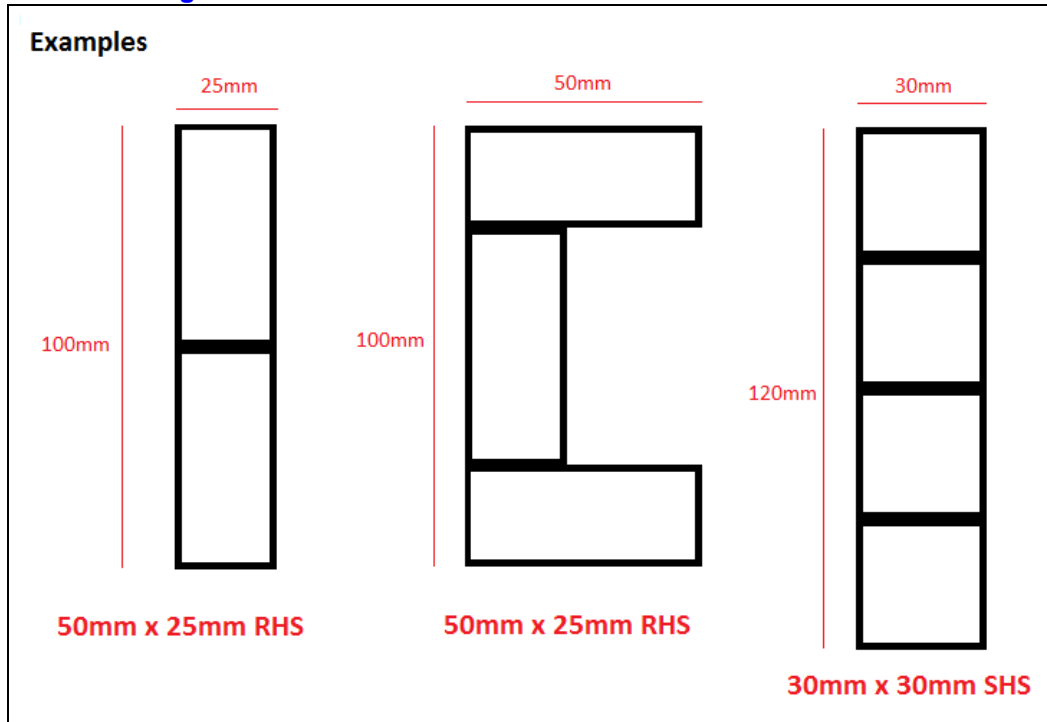

**Technical Diagram 09**

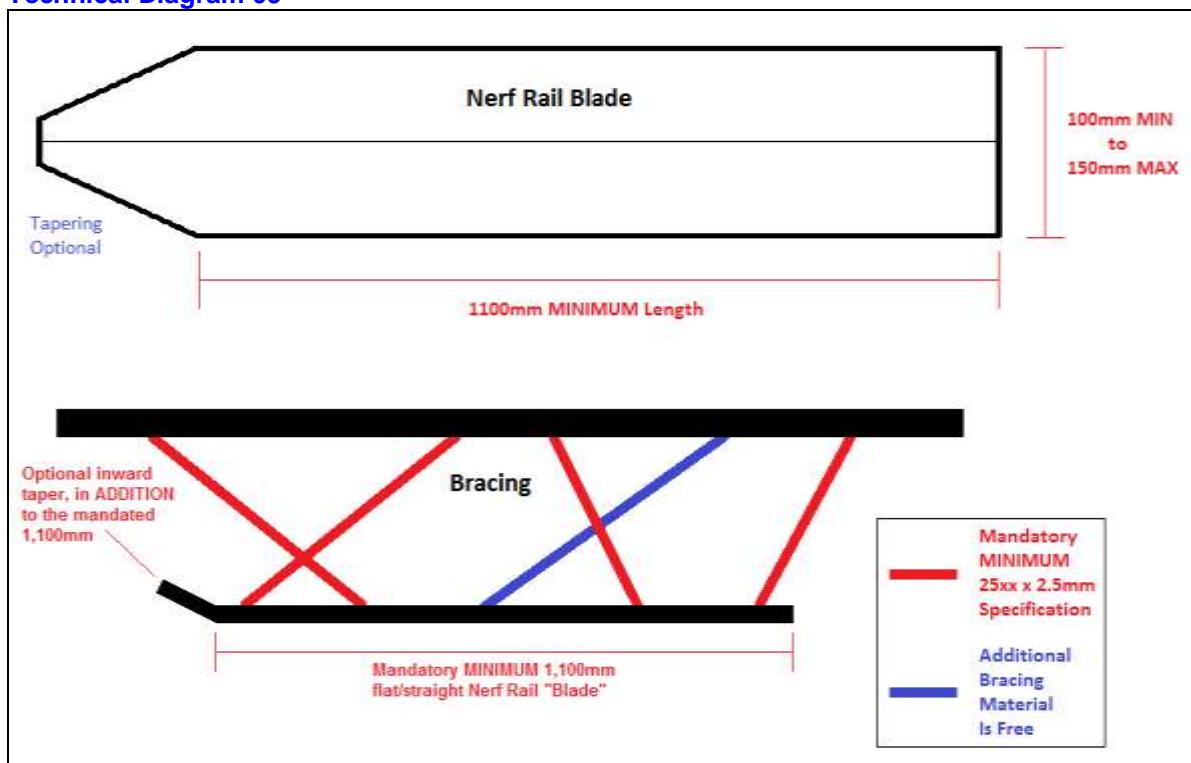

**Nerf-Rail Blade Mounting/Bracing**

**205.16** The nerf-rail blade MUST be connected/braced to the main chassis rail, by a MINIMUM of four (in number) braces on each side of the car. [This is illustrated in Technical Diagram 09.](#)

**205.17** The nerf-rail blade MUST be connected/braced to the lower under-chassis rail, by a MINIMUM of two (in number) diagonal braces on each side of the car.

- 205.18** The 6 mandated braces MUST be constructed from a MINIMUM material specification of 25mm CHS/SHS, with a MINIMUM wall thickness of 2.5mm.
- 205.19** The crossing of braces is permitted.
- 205.20** Where a side-pod is installed, it IS permitted to brace the nerf-rail to the side-pod construction material, rather than directly to the lower chassis rail on that side of the car.
- 205.21** Additional bracing (over and above the 6 mandated braces above) is free in both quantity and material specification.

#### Miscellaneous

- 205.22** Any additional brackets required for mounting the mandated wheel-guard MUST be in addition to the mandated minimum material dimensions above.
- 205.23** The drilling and sleeving of a single circular hole at the rear of the nerf-rail, with a MAXIMUM diameter of 35mm, for the express purpose of socket access to a wheel-guard mounting bolt is permitted.
- 205.24** The cutting and sleeving of a square/rectangular hole within the nerf-rail blade face, for the purpose of mounting the wheel-guard through, is permitted. Any such hole must NOT be larger than a MAXIMUM of 75mm in height and 100mm in length.
- 205.25** Any additional optional material attached to the nerf-rail, e.g. a fuel tank protection plate, or protection bars, must only be constructed within an area bordered by the main/lower chassis rails, the side-pod, the nerf-rail, the nerf-rail bracing to the main chassis, and a straight line connecting the lower outermost point of the side-pod to the lower innermost point of the nerf-rail. This is illustrated in Technical Diagram 10.

**Technical Diagram 10**

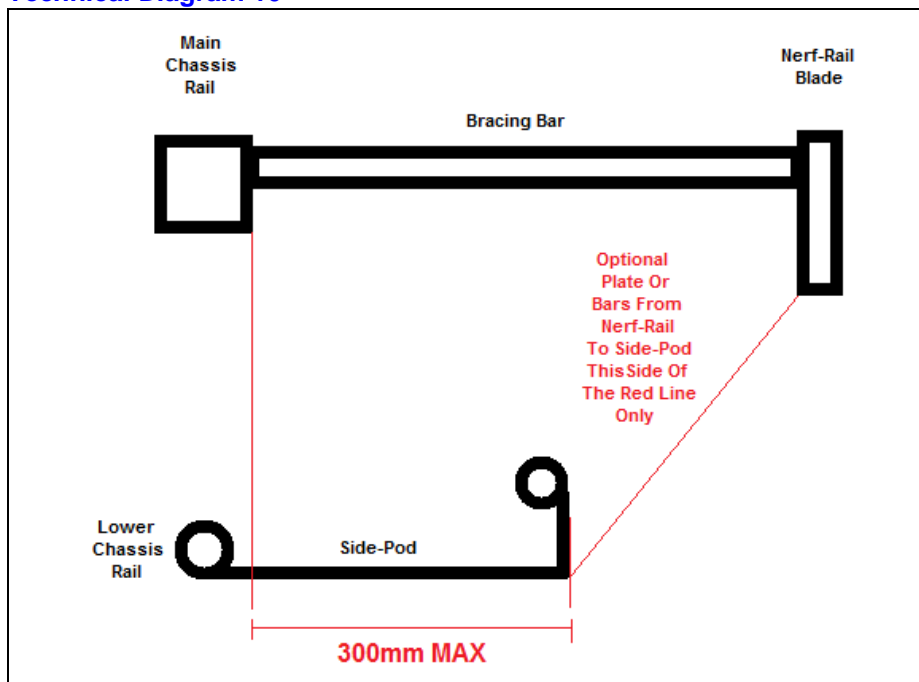

## 206 Wheel-Guards

- 206.01** A single solid steel wheel-guard MUST be fitted around the offside (right) rear wheel, from the rear bumper to the nerf-rail.
- 206.02** The wheel-guard MUST be similar in dimensions to the Ford Transit or Ford Escort rear leaf spring with a MAXIMUM permitted height of 3in (75mm).
- 206.03** The wheel-guard MUST be bolted to its mounts at BOTH ends using high-tensile nuts and bolts of a MINIMUM 12mm diameter. Where an original leaf spring incorporating a rubber/polyurethane bush at one end is used as a wheel-guard and a mounting bolt runs vertically through the bush, a MINIMUM diameter 10mm bolt is permitted, but it MUST be mounted in double-shear. An example [guide to fitment is illustrated in Technical Diagram 11](#).
- 206.04** Incorporating an element of protection for protruding bolt heads, with the aim of preventing them from being sheared off, is permitted.
- 206.05** The drilling and/or lightening of the wheel-guard, except for mounting-bolt holes, is NOT permitted.
- 206.06** Where an original leaf-spring is used to form a wheel-guard, then any original mounting/location hole(s) in the leaf spring are permitted and should NOT be welded up (due to the heat of the welding process having a potentially adverse effect on the strength of the sprung-steel material).

**206.07** The use of a single wheel-guard on the nearside (left) rear wheel is optional, but if fitted it MUST conform to the above regulations.

**Technical Diagram 11**

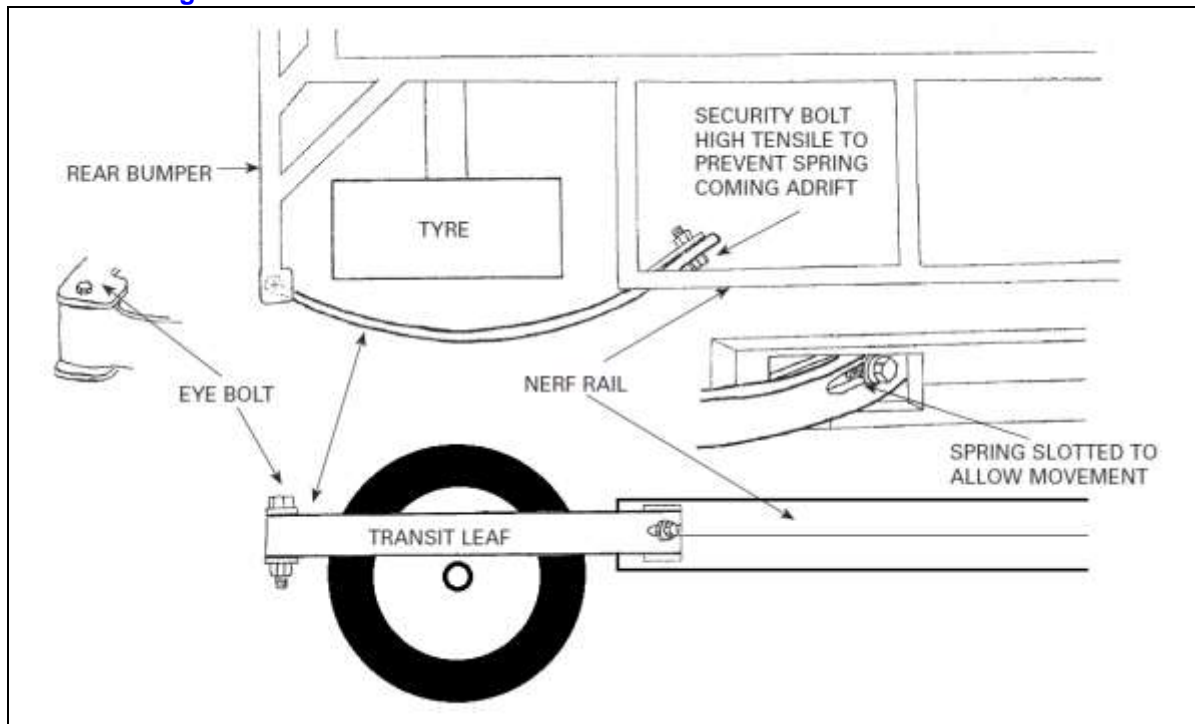

## 207 Engine Firewall

**207.01** A complete firewall MUST be installed between the engine and the driver's compartment to help protect the driver from the possibility of burns from fire, fuel, oil or water.

**207.02** The firewall MUST be made of metal.

**207.03** The firewall MUST be complete except for minimal sized holes through which essential cables, pipes or the steering column are required to pass.

## 208 Floors and Side-Pods

### General Regulations

**208.01** Exposed edges of plate, which could act in a knife-like manner, are NOT permitted.

**208.02** Floor sections under the main chassis/undercarriage footprint are NOT permitted, unless explicitly detailed below, e.g. in the driver's cab area, or under a permitted side-pod.

**208.03** Any chassis floor section must NOT extend outside of the footprint of the lower/under-chassis, unless explicitly permitted below, e.g. under a side-pod.

**208.04** The construction/installation of any floor section outside of the footprint of the main/lower chassis rails and cross-members, other than as specified below is NOT permitted. E.g. steel plate around the left-front wheel area.

### Side-Pods

**208.05** For the purpose of these regulations, a side-pod is deemed to include any, but not necessarily all, of the following constituent parts where fitted/constructed, and therefore such constituent parts must be included within any dimensional regulations set out below:

- Floor section
- Side wall(s), whether solid or constructed from hollow section
- Framework
- Cover
- Bracing to the undercarriage/lower-chassis
- Panel-work surrounding/protecting the construction

**208.06** The installation of any side-pod, outside of the footprint of the main/lower chassis rails is ONLY permitted for the purpose of mounting/protecting any fuel-tank and/or battery mounted in such a location. Side-pods are NOT permitted for any other purpose.

- 208.07** The incorporation of mounting points for suspension link bars, anti-tramp bars, and/or leaf-springs, in to the construction of any side-pod, IS permitted where such components would ordinarily be mounted to other steelwork/brackets protruding from the chassis/undercarriage in the absence of a side-pod.
- 208.08** A MAXIMUM of one external side-pod, outside the main/lower chassis rails, is permitted on each side of the car.
- 208.09** The MAXIMUM permitted thickness of any side-pod floor fitted in the same horizontal plane as the cab floor is 4mm. Any other plating must conform to the general car construction material regulations in place.
- 208.10** Any side-pod must NOT extend any further than a MAXIMUM of 300mm out sideways from the vertical plane of the main chassis rail at any and all points.
- 208.11** The MAXIMUM permitted front to rear length of any side-pod, outside of the main/lower chassis rails is 1,000mm at any and all points.
- 208.12** Any side-pod, outside of the main/lower chassis rails, including any material/bracing connecting it to any part of the undercarriage below the level of the main chassis rail, MUST only sit between the front and rear wheels, when viewed from the side/above.
- 208.12.01** The side-pod MUST NOT be constructed any further forward than the vertical plane of the rear-most point of the front wheel/tyre (when pointed straight ahead).
- 208.12.02** The side-pod MUST NOT be constructed any further rearward than the vertical plane of the front-most point of the rear wheel/tyre.
- 208.13** The entire side-pod, outside of the main/lower chassis rails, including any material/bracing connecting it to any part of the undercarriage below the level of the main chassis rail, MUST fit within an imaginary rectangular box measuring 1,000mm in length by 300mm in width, as illustrated in [Technical Diagram 12](#).
- 208.14** Bracing from the side-pod up to the main chassis rail and/or the nerf rail only, is permitted to extend outside the 1,000mm x 300mm box defined above, and outside the area between the wheels.
- 208.15** Any permitted side-pod/floor section outside the main/lower chassis rails must be constructed with no more than a SINGLE floor section, and no more than a SINGLE outer wall section.
- 208.16** The “zig-zagging” or multiple folding of plate, or construction using multiple sections of plate, to form channels, multiple walls or floor sections, or additional internal wall or floor sections, or any other sections not for the purpose of supporting or protecting the fuel tank and/or battery is NOT permitted.

**Technical Diagram 12**

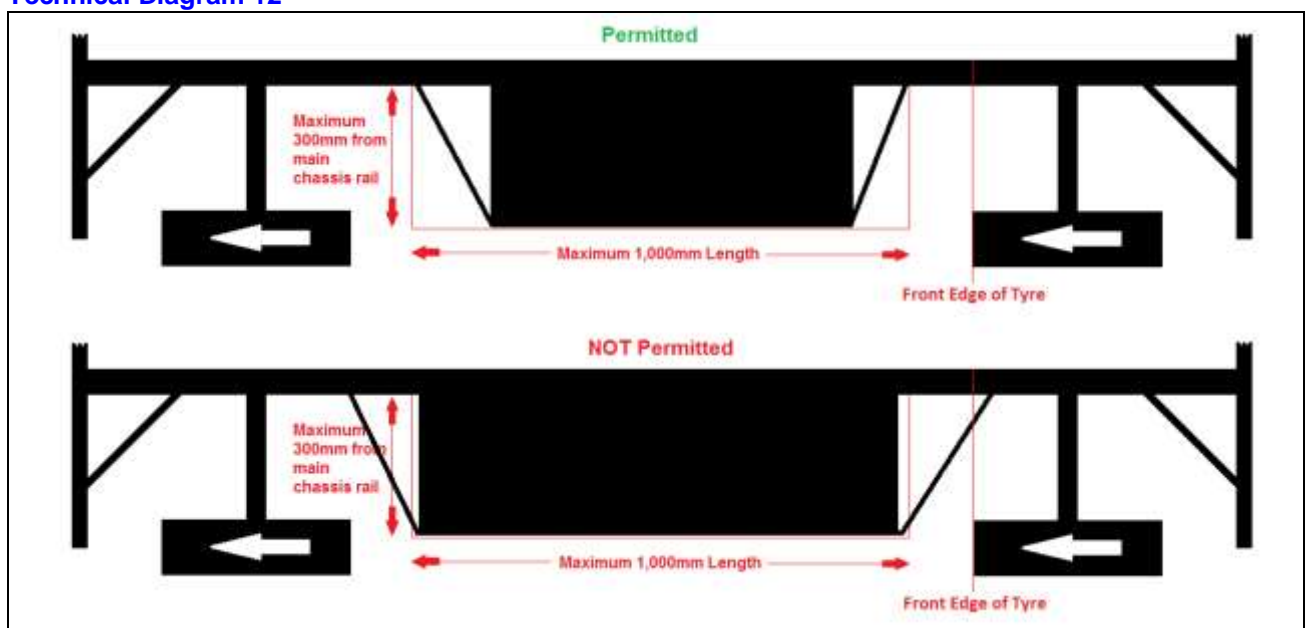

### Cab Floor

- 208.17** A solid floor MUST be installed in the driver's compartment (cab) to protect the driver.
- 208.18** Where any part of the floor of the driver's compartment is below the bottom of the main chassis rails, OR there is not a full under chassis, the cab floor MUST be constructed of 3mm MINIMUM thickness steel plate. Aluminium is NOT permitted in this case.
- 208.19** Where the entire floor of the driver's compartment is above the bottom of the main chassis rails AND a full under chassis is present (i.e. lower rails extending to at least level with the front edge of the driver's seat, the cab floor MUST be constructed of either 3mm MINIMUM thickness aluminium plate (including chequered plate) or 3mm MINIMUM thickness steel plate.

- 208.20** The MAXIMUM permitted thickness of the cab floor is 4mm.
- 208.21** The cab floor MUST extend rearwards from the vertical plane of the engine bulkhead firewall. It is NOT permitted to extend forwards of the engine bulkhead firewall.
- 208.22** The cab floor must measure at least a MINIMUM of 600mm in length, and no more than a MAXIMUM of 800mm in length, from the engine bulkhead firewall, over its entire width.
- 208.23** The cab floor MUST extend rearwards BEYOND the point at which it overlaps in a vertical plane (across the entire width of the car) with the front edge of the driver's seat.
- 208.24** The cab floor MUST cover the full width of the area between the chassis rails along the floor's entire length.
- 208.25** The cab floor MUST be either welded to the chassis, or attached using a MINIMUM of eight (in number) high tensile 8mm nuts and bolts.
- 208.26** Cutting of the cab floor around the bell-housing and gearbox for fitment is permitted. NO other drilling or lightening is allowed.
- 208.27** The front edge of the cab floor may be angled upwards to prevent catching on high kerbs or other obstacles should car design require this.
- 208.28** The rear of the cab floor may be folded/curved up for strength, or to meet a seat/chassis cross-member, subject to the length requirements above.

#### **Sump-Guard**

- 208.29** The use of a sump-guard is permitted, but it MUST be constructed from steel or aluminium.
- 208.30** The sump-guard is permitted to be integral to the permitted cab-floor, subject to compliance with the regulations in relation to the placement and coverage of the cab floor.
- 208.31** The MAXIMUM permitted thickness of a steel sump-guard is 4mm.
- 208.32** The MAXIMUM permitted thickness of an aluminium sump-guard is 5mm.
- 208.33** The MAXIMUM permitted width of the sump-guard plate is 300mm at any point along its length.
- 208.34** The longitudinal centre-line of the sump-guard must NOT be any further to the left of the car than the centre-line of the engine.

## **209 Foot Protection Plating**

- 209.01** Where ANY part of the driver's legs or feet are located below the bottom of the main (top) chassis rail a vertical side protection plate of 3mm thickness steel MUST be welded between the main (top) and lower chassis rails to cover the entire side area of the driver foot-well on both sides of the car.
- 209.02** Where a driver's legs and feet are located entirely above the bottom of the main (top) chassis rails a vertical side protection plate of 2mm MINIMUM thickness steel MUST be welded between the main (top) chassis rail and the level of the main cab window side-bars to cover the entire side-area of the driver's legs/feet position.
- 209.03** Where a driver's feet are located such that they are both above and below the main (top) chassis rails then steel vertical side protection plates MUST be mounted BOTH between the main (top) and lower chassis rails, AND between the main (top) chassis rail and the level of the main cab window side bars. These protection plates MUST conform to the individual plate regulations above.
- 209.04** In all cases, the side protection plate MUST extend rearwards from the engine bulkhead firewall in front of the driver's feet for a MINIMUM distance of 500mm over its entire height.
- 209.05** In all cases, the side protection plate MUST extend rearwards to a point such that its ENTIRE rear edge is located level with or behind the vertical plane from the front edge of the driver's seat.
- 209.06** The side protection plates must NOT be drilled or lightened in any way, except for minimal sized holes through which essential electrical cables or fuel pipes are required to pass.

## **210 Driver's Seating & Harness**

### **210.01 Driver**

- 210.01.01** The driver MUST be seated along the centre-line of the car.
- 210.01.02** The driver MUST be seated in front of the rear axle.
- 210.01.03** ALL parts of the driver's body MUST be entirely behind the rear of the engine cylinder block.
- 210.01.04** The driver MUST be able to exit the car through BOTH sides of the cab whilst wearing all safety equipment used for racing (e.g. Helmet, overalls, gloves, head/neck restraint).

### **210.02 Seat**

- 210.02.01** The seat MUST be of a bucket type design, incorporating a base, back, and side-support for the driver's body. The use of appropriate padding, moulded inserts, or other fitting materials, to ensure a good fit to the driver, is permitted. It is the driver's responsibility to ensure the seat is an appropriate fit.
- 210.02.02** The seat MUST be upright when viewed from the front/rear of the car.

- 210.02.03** The seat **MUST** be securely fitted to the car along the car's centre-line to a tolerance of +/- 5mm either side from centre.
- 210.02.04** Central fitment is measured by taking the distance from the transverse horizontal centre of the seat to the inside edge of the main chassis rail on each side of the car. This distance **MUST** be equal on both sides of the car to within +/-10mm of each other, i.e. the two measurements **MUST** be within 10mm of each other, thus giving a **MAXIMUM** tolerance of central fitment of +/-5mm from the centre-line of the car. **BOTH** the front and rear edges of the seat **MUST** be within the stated tolerances.
- 210.02.05** The seat **MUST** be securely fitted to the car using high-tensile bolts of a **MINIMUM** 8mm in diameter.
- 210.02.06** The seat **MUST** be supported/protected at the base, back and any integral headrest to prevent major deformation and/or movement in a high-energy impact.
- 210.02.07** Any cross-member(s)/support-bar(s) for mounting/supporting/protecting the seat **MUST** be integral to the chassis/roll-cage structure and be fully welded at all joints.
- 210.02.08** Any lower cross-member installed for the purpose of mounting the seat is permitted to drop down below the level of the main chassis rails or be profiled to the seat to allow for correct fitment.
- 210.02.09** The seat **MUST** be fitted to the car with reference to the individual seat manufacturer's/supplier's information, and particular attention **MUST** be paid to key items such as the fittings used, the seat angle, the layback, safety harness strap placement, etc.
- 210.03 Seat Protection Plate**
- 210.03.01** A rectangular steel protection plate **MUST** be bolted to the base of the seat, or welded to the chassis directly under the seat to protect the driver from the rear-axle, differential, and prop-shaft. The mandated protection plate **MUST** be in **ADDITION** to the base of the seat, thus providing a double layer of protection.
- 210.03.02** The protection plate **MUST** be a **MINIMUM** of 3mm in thickness, and measure a **MINIMUM** of 350mm wide along its entire length, and a **MINIMUM** of 250mm front to back across its entire width.
- 210.03.03** The protection plate must **NOT** be drilled, lightened, or modified in any way other than to mount it to the seat/chassis.

**Technical Diagram 13**

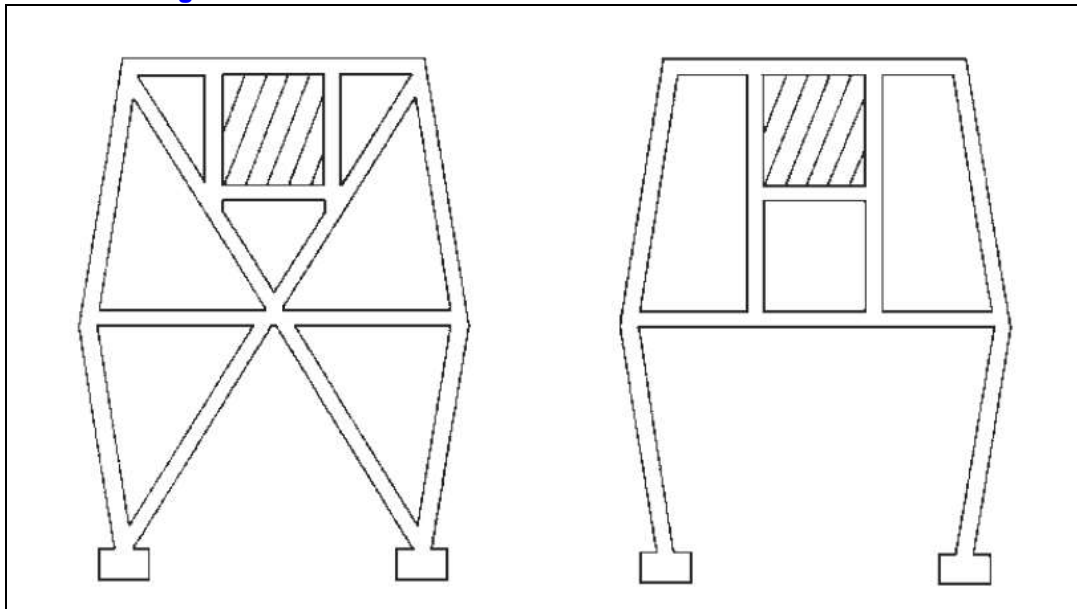

**210.04 Headrest**

- 210.04.01** Two "headrest" bars **MUST** be installed behind the driver's head/helmet to either (i) support and protect the headrest of a fully integral racing seat, or (ii) allow the mounting of a mandatory headrest plate in cases where the seat does not incorporate a headrest. These headrest bars **MUST** be symmetrical and run in a top to bottom orientation when viewed from the rear. Care should be taken to ensure they do not impede the safe installation of the driver's safety harness.



- 210.04.02** The headrest bars **MUST** be constructed of steel, be an integral part of the roll-cage construction, and be fully welded to cross-members at the top and bottom. [Example designs are illustrated in Technical Diagram 13.](#)
- 210.04.03** The headrest bars must **NOT** protrude from the main roll-cage in side-profile (pillars 3 & 4).
- 210.04.04** If the driver's seat does not incorporate an integral headrest, then a steel headrest plate **MUST** be fitted.
- 210.04.05** The headrest plate **MUST** be welded along its left and right vertical edges to the two headrest bars located behind the driver's head/helmet (specified above).
- 210.04.06** The headrest plate **MUST** be a **MINIMUM** of 3mm thick steel plate.
- 210.04.07** The headrest plate **MUST** measure between 150mm and 200mm square.
- 210.04.08** The headrest plate must **NOT** be drilled, lightened, or modified in any way.
- 210.04.09** The headrest bars and any headrest plate **MUST** be located within the roll-cage profile such that a horizontal straight-edge can be simultaneously butted up against the left rear and right rear roll-cage corner pillars (pillars 3 & 4) at any point along their profile length, from where they meet the main chassis at their base, to the roof-bars at the top. Any headrest bar and/or headrest plate preventing a horizontal straightedge from contacting the left and right rear roll-cage pillars simultaneously is **NOT** permitted.

## **210.05 Safety Harness**

- 210.05.01** The car **MUST** be fitted with a quick-release motorsport type safety harness to hold the driver in to the seat.
- 210.05.02** The safety harness **MUST** be worn at all times when on track, racing or practising.
- 210.05.03** Regulations regarding the correct specification, fitment, and use of the safety harness are produced by the ORCi to ensure consistency and best practice across all oval formulas. The ORCi safety specifications are detailed separately in these regulations, and unless explicitly stated below, the ORCi regulations apply.
- 210.05.04** The safety harness **MUST** consist of a **MINIMUM** of two separate shoulder straps, two separate lap straps, and an "anti-submarine" crotch strap (sometimes referred to as a sub-strap). The safety harness **MUST** be of either a 5-point or 6-point design.
- 210.05.05** The safety harness **MUST** be anchored to the car's chassis by one of the following methods:
- Attached to bolt-on or weld-on purpose-made ringed harness eyelets using the harness manufacturer's original components, and to their specification.
  - Securely buckled around integral roll-cage or chassis cross-members using the harness manufacturer's original components, and to their specification. Any such cross-member(s) **MUST** be welded to other fixed chassis/roll-cage bars at both ends such that the safety harness cannot become detached, and **MUST** conform to the **MINIMUM** roll-cage material specifications.
  - Attached as per original installation instructions provided by the harness manufacturer. The driver **MUST** be able to demonstrate installation conformance to manufacturer's instructions if requested by BriSCA F2 and/or its appointed officials.
- 210.05.06** The harness must **NOT** be mounted or attached to the seat protection plate.
- 210.05.07** The safety harness **MUST** be installed using standard original manufactured hardware designed for this purpose, e.g. mounting eyes and buckles. The use of chain, D-links, karabiners, or other non-approved components not originally designed for harness installation is **NOT** permitted.
- 210.05.08** A **MAXIMUM** of one strap attachment is permitted to any single bolted mount point or bolt/weld-on ringed harness eyelet, e.g. separate lap and anti-submarine straps must **NOT** be mounted to the same eyelet. It is permitted to mount multiple straps around a single integral cross-member, e.g. the shoulder straps to a cross-bar.
- 210.05.09** The shoulder straps **MUST** be supported at shoulder level to prevent deformation/compression of the seat and driver injury in a high-energy impact.
- 210.05.10** All anchorage points **MUST** be easily accessible for scrutineering purposes.

## **210.06 Driver Protection**

- 210.06.01** All chassis cross-members located between the engine firewall and the front edge of the driver's seat, which may be impacted by the driver's legs (and especially the shins) during an impact, **MUST** be protected by high-density foam with the intention of preventing leg injuries.

## **211 Foot Pedals**

- 211.01** The car **MUST** have only **ONE** pedal each to operate the clutch, brake and throttle.
- 211.02** Left-foot braking is **NOT** permitted.

- 211.03** The clutch pedal **MUST** be fitted to the **LEFT** side of the bell-housing/gearbox where the floor of the cab is located below the level of the main gearbox input shaft.
- 211.04** The clutch pedal **MUST** be fitted to the **LEFT** side of the car's centre-line where the floor of the cab is located above the level of the main gearbox input shaft.
- 211.05** The brake and throttle pedals **MUST** be fitted to the **RIGHT** side of the bell-housing/gearbox where the floor of the cab is located below the level of the main gearbox input shaft.
- 211.06** The brake and throttle pedals **MUST** be fitted to the **RIGHT** side of the car's centre-line where the floor of the cab is located above the level of the main gearbox input shaft.
- 211.07** Where the floor of the cab is located above the level of the main gearbox input shaft a metal panel **MUST** be fitted between the clutch and brake pedals to prevent the driver from using their left foot on the brake pedal.

## **212 Track Width**

### **212.01 Track Width**

- 212.01.01** The track width of an axle is measured in the vertical plane along the transverse centreline of the axle and is the measurement between the outermost extremities of the tyre/wheel assemblies on that axle. The measurements **EXCLUDE** any wheel-guards.
- 212.01.02** The **MAXIMUM** permitted track width is 68in (1728mm) for both the front and rear axles.
- 212.01.03** The track width **MUST** be set such that the axle would pass in a straight line between two fixed posts/walls that are 68in (1728mm) apart.

### **212.02 Checking Procedure**

- 212.02.01** In practice the nerf-rails (which are permitted to extend beyond the edge of the tyres) may physically prevent the passing of the car between two fixed posts/walls. Checking of these regulations may therefore be carried out using a fixed width gauge placed over/around the wheels and tyres.
- 212.02.02** The gauge **MUST** be able to fit over the wheels/tyres with **NO** forced deflection of the tyre/wheel assembly.
- 212.02.03** Forced deflection of the tyre/wheel assembly in order to make the gauge fit is regarded as a **FAILURE** to adhere to the regulations.

### **212.03 Track Width Penalties**

- 212.03.01** The penalties for track width infringements are detailed in the Technical Infringement Penalties section of these regulations.

## **213 Suspension – Shock Absorbers (Dampers) and Springs**

### **213.01 Shock Absorbers (Dampers)**

- 213.01.01** A **MAXIMUM** of one shock absorber (damper) per wheel/corner is permitted.
- 213.01.02** A **MAXIMUM** of four shock absorbers per car are permitted.
- 213.01.03** Mono-tube shock absorbers are **NOT** permitted for use.
- 213.01.04** Remote reservoirs are **NOT** permitted for use.
- 213.01.05** A **MAXIMUM** of **ONE** adjustment device per shock absorber is permitted.
- 213.01.06** The mounting of shock-absorbers in-board or out-board of the main chassis rails is permitted.
- 213.01.07** Each individual shock absorber (damper) **MUST** be mounted predominantly below the level of the main chassis rails. In practice this means that at least half the length of each shock absorber (measured between the centre of the top and bottom mounting bolts/bearings/brackets), when the car is at rest, must be below the top of the main chassis rail adjacent to where the shock absorber is mounted.

### **213.02 Springs**

- 213.02.01** A **MAXIMUM** of one spring per wheel/corner is permitted. This may **EITHER** be a single coil spring, **OR** a single leaf spring unit (see below).
- 213.02.02** A multi-leaf spring in a single unit counts as a single spring for the purpose of these regulations.
- 213.02.03** A **MAXIMUM** of four springs per car are permitted – one per corner.

### **213.03 Coil Springs**

- 213.03.01** Coil springs **MUST** be made of steel.
- 213.03.02** Conical coil springs are **NOT** permitted.
- 213.03.03** Coil springs **MUST** be constant in internal and external diameter over their entire length, i.e. they must **NOT** taper in or out at any point.
- 213.03.04** Coil springs **MUST** be constant in diameter of the spring material over their entire length.
- 213.03.05** The use of helper springs is **NOT** permitted.



**213.03.06** If a coil spring is mounted independently to a shock absorber (damper) then it **MUST** be mounted predominantly below the level of the main chassis rails. In practice this means that at least half the length of the coil spring (measured between the top and bottom faces of the spring, when the car is at rest, must be below the top of the main chassis rail adjacent to where the coil spring is mounted.

#### **213.04 Leaf Springs**

**213.04.01** Leaf springs **MUST** be made of steel.

**213.04.02** Rear-axle leaf springs **MUST** be mounted longitudinally, outside of the chassis rails. Transversely mounted leaf springs are **NOT** permitted on the rear-axle.

**213.04.03** The front (chassis) mount of any rear-axle leaf spring **MUST** be fixed. Sliding mounts are **NOT** permitted.

**213.04.04** Front-axle leaf springs may be mounted longitudinally, or transversely.

#### **213.05 Device Adjustment**

**213.05.01** Any devices which allow adjustment of the spring platforms, shock absorbers, and/or anti-roll bar(s) by the driver from within the cab are **NOT** permitted.

## **214 Front Axle/Suspension**

### **214.01 Axle**

**214.01.01** It is permitted to use either a solid beam-axle, or an independent design for the front axle/suspension.

**214.01.02** Front uprights, brake discs and hubs must **NOT** be offset in any way.

**214.01.03** Differing King-pin inclinations are permitted on each side of the car.

**214.01.04** The use of bird-cage fitments is **NOT** permitted.

### **214.02 Independent Front Suspension**

**214.02.01** The top wishbones (including any spherical bearings/rose-joints) **MUST** be of equal length on both sides of the car. This measurement is taken from the centre of the bearing/pivot point on the upright mounting, to the centre of the bearing/pivot point axis on the chassis mounting.

**214.02.02** The top-wishbone mounting brackets **MUST** be symmetrical about the chassis rails/car centre-line, in design, installation location, and distance from the centre-line, when viewed from the front/rear.

**214.02.03** The transverse fitment position of the top-wishbones in their mounting brackets **MUST** be symmetrical about the chassis rails/car centre-line, when viewed from the front/rear. That is, the inset/outset of the wishbones, relative to the chassis rails/car centre-line, **MUST** be equal on both sides of the car.

**214.02.04** The vertical fitment position of the top-wishbones in their mounting brackets, relative to the ground/chassis, may be different on each side of the car, if desired. E.g. one side in an upper mounting hole, the other side in a lower mounting hole.

**214.02.05** Camber **MUST** only be set/adjusted by altering the length of the bottom wishbone/track control arm.

**214.02.06** ALL independent front suspension mounting components, including but not limited to bottom arms, compressions struts, wishbones, and shock absorber rockers **MUST ONLY** be mounted to the chassis (at the component's pivot point) on the same side of the chassis centre-line as the wheel they support.

### **214.03 Solid Beam Axle**

**214.03.01** Beam axles **MUST** be centrally fitted transversely in the chassis to a tolerance of +/-5mm either side from the centre.

**214.03.02** Central fitment will be measured using the distance from the rotational centre at the top of the king-pins to the outside edge of the main chassis rails on each side of the car when viewing the car from the front. This distance **MUST** be equal on both sides of the car to within +/- 10mm of each other, i.e. the two measurements **MUST** be within 10mm of each other, thus giving a **MAXIMUM** tolerance of central fitment of +/-5mm from the centre-line of the car.

**214.03.03** The alteration of camber angles is permitted.

**214.03.04** The use of a 2-piece beam axle is permitted, but the 2 sections **MUST** be securely fastened together to prevent them coming apart.

**214.03.05** Radius arms mounting the beam axle to the chassis must **NOT** cross the centre-line of the chassis.

### **214.04 Hubs**

**214.04.01** Front hubs **MUST** be made of a ferrous material.

## 215 Rear Axle/Suspension

### 215.01 Axle

- 215.01.01 The rear axle MUST be of rigid normal production type (similar in pattern to the Ford Escort Mk1/2).
- 215.01.02 The rear axle must NOT be wider than the Ford Cortina Mk3/4/5 axle when measured from the outside of wheel flange to wheel flange.
- 215.01.03 The axle tubes (between the differential carrier and the end flanges) MUST be of equal length.
- 215.01.04 The rear wheels must NOT be cambered in any way.

### 215.02 Axle Alignment

- 215.02.01 The rear axle MUST be centrally fitted transversely in the car. A tolerance of +/-5mm either side from centre is permitted to account for race damage.
- 215.02.02 Central fitment is measured by taking the distance from the inner edge of the rear wheel rim to the outside edge of the main chassis rail on each side of the car. This distance MUST be equal on both sides of the car to within +/-10mm of each other, i.e. the two measurements MUST be within 10mm of each other, thus giving a MAXIMUM tolerance for central fitment of +/-5mm from the centre-line of the car.
- 215.02.03 Steering of the rear axle by lengthening or shortening the wheelbase is permitted.

### 215.03 Half-Shafts

- 215.03.01 The half-shafts MUST be of equal length.
- 215.03.02 The bearing retaining collar on the nearside (left) MUST be tack welded to the half-shaft, if it is only a press fit, to prevent the half-shaft from pulling out.

### 215.04 Fitting/Installation

- 215.04.01 The rear axle MUST be installed and sprung (i) using leaf springs, with anti-tramp bars if required, or (ii) by a traditional 4-link method using two separate link bars on each side of the car with coil-over springs and a lateral location device.
- 215.04.02 ALL rear axle mounting/location components MUST be fitted OUTSIDE of the vertical planes taken from the inner edges of the main chassis rails. NO rear axle mounting/location components may be fitted inside/between the inner edges of the chassis rails with the exception of (i) a Panhard Bar or Watts Linkage (see below), and/or (ii) in-board mounted coil-over shock absorbers (see below).
- 215.04.03 The rear axle MUST be installed and fitted such that the failure/disconnection of any one mount/joint will not cause the axle to rotate at any time (either when static, or under load) resulting in the differential/prop-shaft hitting the seat.
- 215.04.04 The rear axle/differential/prop-shaft must NOT be able to contact the driver's seat if the rear shock absorbers are disconnected and/or compressed to their maximum compression point, and the axle subsequently raised to its highest possible point. This applies to the car in any orientation, not just with the chassis resting on the ground, and therefore may be checked by resting the wheels on blocks in order to lower the chassis/raise the axle further.
- 215.04.05 It is permitted to add additional material (e.g. a piece of RHS, or a dense rubber block) to the underside of the chassis rail, or the top of the axle casing, in order to prevent contact with the seat.

### 215.05 Mountings

- 215.05.01 All rear axle mounting components (including, but not limited to, link, anti-tramp, Panhard and Watts Linkage bars) MUST be bolted to separate fixed points on the chassis and axle.
- 215.05.02 Bolting/mounting more than one component to a single point is NOT permitted.
- 215.05.03 The use of rotating, sliding, or other minutely adjustable mounting devices, or any slotted mounts is NOT permitted – This includes, but is not limited to, the use of vertically mounted bolts with replaceable/removable washers/spacers that would allow height adjustment of the end of a link bar, even if only a single bolt/set of chassis holes is utilized.
- 215.05.04 The use of oversize mounting holes (in relation to the bolt size) and/or undersize bolts (in relation to the mounting holes) is NOT permitted.
- 215.05.05 The use of original, or modified, adjustable mounting components, e.g. aluminium sliders, is NOT permitted, even if mounted to fixed points.
- 215.05.06 The use of any "changeable specification mounting component" design is NOT permitted. This includes, but is not limited to:
  - The use of changeable plates incorporating the mounting holes.
  - Multiple mounting locations that would require the removal and installation of different length link bars.

- Adjustable length link bars. (The normal small range of link bar adjustment provided by a standard design rose-joint is permitted).
- Vertically mounted bolts for rose-joints with changeable varying thickness washers/spacers.

### **215.06 Link Bars and Anti-Tramp Bars**

- 215.06.01** All rear axle link and anti-tramp bars **MUST** be constructed of steel or aluminium, and, where required, utilise steel or aluminium rose-joints/bearings.
- 215.06.02** All rear axle link and anti-tramp bars **MUST** be of solid fixed-length construction, such that their length cannot change/be changed under load during racing (i.e. **NO** springs, damping or telescopic devices).
- 215.06.03** The use of adjustable mounting bearings (e.g. a threaded rose-joint) at the end(s) of a link or anti-tramp bar that allows total length adjustment off-track is permitted.
- 215.06.04** The use of rubber or polyurethane bushes in the mounting of rear axle link and anti-tramp bars is permitted.

### **215.07 Lateral Location**

- 215.07.01** Lateral location of the rear axle may be achieved by the use of a Watts Linkage, or Panhard Bar only.
- 215.07.02** Any Panhard Bar or Watts Linkage **MUST** be fitted behind the axle casing and below the main chassis rails.
- 215.07.03** The use of an A-Frame for lateral rear axle location is **NOT** permitted.

### **215.08 Strengthening**

- 215.08.01** The rear axle casing may be strengthened through the use of welded or bolted-on bracing. The use of adjustable bracing is permitted.
- 215.08.02** The use of links incorporating rose-joints or other threaded/adjustable bearings/fixings/fittings is permitted for the purpose of strengthening the casing, and/or adjusting out race-damage and the effects of heat from welding brackets etc.
- 215.08.03** The use of rubber/poly bushes in a bolted brace, to allow a small amount of flex under shock load, is permitted.

### **215.09 Torque Arms/Birdcages**

- 215.09.01** The use of torque arms is **NOT** permitted.
- 215.09.02** The use of bird-cage fitments is **NOT** permitted.

## **216 Wheel Rims and Wheel-Nuts**

### **Wheels**

- 216.01** All cars **MUST** have 4 wheels.
- 216.02** Wheel rims **MUST** be made of steel or alloy, and be the correct fitment for the hub/stud-pattern being used.
- 216.03** An alloy wheel rim, if used, **MUST** be one of the following:
- a genuine vehicle manufacturer/OEM rim
  - a mass-produced aftermarket rim
  - a manufactured motorsport competition rim
- 216.04** All wheel rims **MUST** remain as originally manufactured unless explicitly stated below.
- 216.04.01** The machining, modification, and/or material alteration of wheel rims from their original manufactured design/production is **NOT** permitted.
- 216.04.02** Examples of prohibited machining/modification include, but are not limited to:
- Radial machining to remove spoke material
  - Radial machining to remove material to allow the fitment of larger brakes
  - Changing material thickness to reduce rotational mass
  - Machining the hub face to alter the original manufactured back-depth.
- 216.05** The banding of steel wheel rims, and/or the narrowing of steel/alloy wheel rims, is permitted. Where a wheel rim is narrowed then any such work must **ONLY** be undertaken on the inner portion of the rim, i.e. the section of rim between the hub/spokes and the chassis rail.
- 216.06** Small repairs to the outer bead or radial sections of wheel rims are permitted.
- 216.07** Repairs to the spoke/hub sections of wheel rims, and/or major structural repairs are **NOT** permitted on safety grounds, and any wheel rims requiring such repairs must **NOT** be used.
- 216.08** The **MAXIMUM** permitted front wheel rim width is 5½J.
- 216.09** There is no **MAXIMUM** or **MINIMUM** limit on rear wheel rim width.
- 216.10** Wheel rim widths **MUST** be equal on **BOTH** ends of each axle, but may vary between the front and rear axles.

**216.11** Wheel back-depths MUST equal on BOTH ends of each axle, but may vary between the front and rear axles.

**216.12** Wheel spacers are NOT permitted on any wheels or axles, whether loose, welded, bonded or bolted.

**216.13** Wheel-balance weights are NOT permitted, and MUST be removed from any wheel prior to use.

#### Open Wheel-Nuts

**216.14** The use of open wheel-nuts is permitted, but all open wheel-nuts MUST be the correct fitment for the wheel rim design and length of stud used.

**216.15** ALL threads of open wheel-nuts MUST visibly engage with the threads of the wheel studs being used.

#### Closed Wheel-Nuts

**216.16** The use of closed wheel-nuts is permitted, but all closed wheel-nuts MUST be the correct fitment for the wheel rim design and length of stud used, e.g. Revolution “tube” nuts, or original Ford wheel-nuts.

#### All Wheel-Nuts

**216.17** The scrutineer, or other appointed BriSCA technical official reserves the right to request the removal of any wheel nuts for closer inspection of the engaged threads to ensure adequate safety.

## 217 Tyres

### HiFly Tyre – HF201

**217.01** *The HiFly HF201 185/70R13 tyre MUST be used on ALL four wheels, on ALL cars, on ALL surfaces from the agreed cutover date (1<sup>st</sup> April 2023 for the UK, 1<sup>st</sup> May 2023 for Mainland Europe), and subject to the regulations below.*

**217.02** *All HiFly tyres must be sourced from an official BriSCA F2 HiFly tyre dealer/sub-dealer, and clearly display the official BriSCA F2/Entyre Supplies identification branding/labelling. Penalties for the use of unmarked tyres, or any tyre sourced from an unapproved supplier are detailed in the “Technical Infringement Penalties” regulations.*

### Yokohama Tyre – Delivery Star RY818

**217.03** The Yokohama Delivery star RY818, labelled as “175R13C – 8PR 97/95P – Delivery Star RY818” MUST be used on the RIGHT REAR wheel (fence-side) only, on ALL cars, on ALL surfaces, subject to the limitations below, *up to the agreed cutover date for the new BriSCA F2 control tyre (last day for use: 31st March 2023 for the UK, 30th April 2023 for Mainland Europe).*

### Yokohama Tyre – A021R

**217.04** The Yokohama A021R tyre, labelled as “185/70R13 A021R” (Pre-2015) or “175/590R13 A021R” (2015-on) ~~may~~ **MUST** be used in its original form, on the front axle and ~~on~~ the LEFT REAR wheel (kerb side) only, subject to the limitations below, *up to the agreed cutover date for the new BriSCA F2 control tyre (last day for use: 31st March 2023 for the UK, 30th April 2023 for Mainland Europe).*

### ~~Avon Tyre – 7.3~~

~~**217.05** The Avon Wide Safety CT 7.3x13 tyre may be used in either treaded or slick form, on the front axle, and/or the LEFT REAR wheel only, subject to the following limitations:~~

~~**217.05.01** **Slicks.** The manufactured slick form of the Avon tyre may be used at any meeting, but on the FRONT axle only.~~

~~**217.05.02** **Treads.** The manufactured treaded form of the Avon tyre may be used at any meeting on the front axle, and/or the LEFT REAR wheel (kerb side) only.~~

~~**217.05.03** **Hardness.** The tyre hardness, measured by a durometer, MUST read 40 or above at ALL times.~~

#### ~~Hardness checking procedure:~~

- ~~• The tyre will be cleaned by hand across the tread.~~
- ~~• The scrutineer or appointed BriSCA F2 Technical Officer will take three durometer readings across the tyre and produce a mean average.~~
- ~~• A mean average below 40 will render the driver liable to penalty.~~

#### ~~Tyre hardness penalties:~~

- ~~• The penalties for tyre hardness infringements are detailed in the Technical Infringement Penalties section of these regulations.~~

### ~~Yokohama Tyres – ALL~~

~~**217.06** The use of tyre softener, chemicals, contaminants, tyre treatment of ANY kind, modification, and/or tampering with the compound of any Yokohama tyre in any way (chemical, physical, or biological) is NOT permitted.~~

#### ~~Softener/treatment/modification checking procedure:~~

- ~~• A chemical “sniffer” may be used to check for the presence of softener, chemicals, contaminants, or treatment products.~~
- ~~• A tyre sample may be taken away for laboratory testing for the presence of softener, chemicals, contaminants, or treatment products.~~

**Softener/treatment/modification penalties:**

- The penalties for tyre infringements are detailed in the Technical Infringement Penalties ~~section of these regulations.~~

**ALL Tyres**

~~217.07 BriSCA F2 reserves the right to change the mandated location on the car of the Delivery Star RY818 tyre, and thus the resulting location(s) of the other tyre options, during the course of the season, with an appropriate notice period of at least 14 days.~~

~~217.08 The same tyre type/model MUST be used on each end of the front axle, but may vary between the front and rear axles.~~

217.09 Tyres must NOT be re-cut, or have their tread pattern altered by siping of the tread blocks.

217.10 Tyre identification marks must NOT be removed.

217.11 Mechanical tyre buffing and surforming is permitted on all permitted tyre types in order to clean up the feathered edges of the tread blocks.

217.12 The use of a standard rubber inner-tube as a method of inflating and maintaining pressure in a tyre is permitted.

217.13 The use of a bead-lock inner-tube, inner-liner, or any other internal device within a tyre is NOT permitted.

217.14 Tyre gaiters may be used on one or both axles subject to the following conditions:

217.14.01 Tyre gaiters MUST ONLY be used on the outside edge of the wheel/tyre assembly – furthest from the chassis.

217.14.02 Tyre gaiters must NOT be used on the inside edge of the wheel/tyre assembly – nearest to the chassis.

217.14.03 If used, tyre gaiters MUST be used on BOTH wheels on an axle. The use of a tyre gaiter on only one wheel on an axle is NOT permitted.

217.14.04 Tyre gaiters are included within the overall track width measurement regulations and MUST therefore pass within any measurement gauges.

217.15 If a tyre check is requested the driver MUST proceed directly ~~round the track~~ to the checking location without delay, otherwise the tyres will be considered illegal.

**218 Brakes**

218.01 A working brake system MUST be fitted.

218.02 Any braking system may be used, subject to the regulations below, but it MUST be in working order.

**218.03 Master Cylinder**

218.03.01 Only a SINGLE braking system master cylinder, with a single bore/piston, single circuit, and single outlet is permitted.

218.03.02 All brake lines MUST be connected to the single brake-line outlet.

218.03.03 Where a master cylinder includes an outlet for a bleed nipple this must NOT be used to connect any brake lines.

218.03.04 The installation/use of multiple master cylinders is NOT permitted.

218.03.05 The installation/use of a master cylinder unit with multiple circuits is NOT permitted.

218.03.06 The installation/use of a master cylinder unit with multiple or differential bores/pistons is NOT permitted.

218.03.07 The MAXIMUM permitted master-cylinder bore size is  $1\frac{1}{8}$  inches (28.58mm).

**218.04 Bias Valves/Levers/Reducers**

218.04.01 Only a SINGLE brake-bias/pressure-reducer/fluid-pressure adjustment device, valve, or lever, with a single input and single output is permitted.

218.04.02 The installation/use of multiple reducers, bias adjusters, or other brake performance altering devices is NOT permitted.

218.04.03 The installation/use of adjusters with multiple input/output connections, and/or multiple bores is NOT permitted.

218.04.04 The installation/use of on/off brake taps is NOT permitted anywhere on the car.

218.04.05 The installation/use of electrically operated bias/shut-off/reduction valves is NOT permitted.

218.04.06 The installation/use of in-line (residual) pressure valves is NOT permitted.

**218.05 Discs and Callipers**

218.05.01 A MAXIMUM of one brake calliper per wheel/corner is permitted.

218.05.02 All brake callipers, whether connected or not, MUST be made of ferrous material.

218.05.03 All brake discs MUST be made of ferrous material.

218.05.04 The MAXIMUM permitted brake disc diameter is **240mm** ~~260mm~~.

218.05.05 **The removal of material from brake callipers, and/or brake calliper carriers (e.g. through grinding, cutting, or drilling) is NOT permitted.**

- 218.05.06** Where a brake calliper is not present for a wheel, the FULL-SIZE original disc MUST remain on the hub/axle/drive-shaft, and the disc MUST be securely attached to the hub/axle/drive-shaft using a MINIMUM of 2 threaded bolts, such that it is prevented from detaching from the axle in the event of a wheel loss.

## 219 Transmission/Final Drive

### Notes for 2023

- BriSCA F2 continues to undertake research into the materials used in all transmission/final drive components.
- The intent is to prevent the introduction/use of expensive lightweight components for performance gain, NOT prohibit acceptable non-ferrous components.
- It is recognised that certain components may be non-ferrous as standard, e.g. brass synchromesh baulk rings, LSD clutch plates, or gearbox tail-housings, and this is being taken in to consideration.
- The review scope covers everything between the gearbox input shaft and the wheel-nuts, and includes (but is not limited to) gearbox internal shafts and gears, differential cages and internals, half-shafts, hubs, and wheel nuts.
- Drivers are advised to check with BriSCA F2 before investing in transmission/final-drive components of a non-ferrous nature during the 2023 season, e.g. an alloy differential cage body.

### 219.01 Materials

- 219.01.01** The gearbox casing, outer differential casing, prop-shaft, rear axle casing, rear axle half-shafts, and rear axle hubs MUST be made of a ferrous material, *unless explicitly permitted*.
- 219.01.02** An aluminium alloy bell-housing, gearbox tail-housing, *and/or original Morris Minor outer differential casing* is permitted.

### 219.02 Gearboxes

- 219.02.01** Quick ratio change gearboxes (defined as gearboxes where ratios are changeable without removing the gearbox from the car) are NOT permitted.
- 219.02.02** Replacement gear kits with different ratios to the original manufacturer's specification are permitted, e.g. Quaife or Tran-X.

### 219.03 Bell-Housing

- 219.03.01** The bell-housing MUST be an original Ford specification component, or a commercially available aftermarket direct replacement.
- 219.03.02** The bell-housing MUST remain as per its original manufactured specification, subject to any permitted/required modifications detailed below.
- 219.03.03** The bell-housing MUST fully enclose the clutch/flywheel assembly around its entire circumference, from the vertical plane of the rear of the engine block to the face of the gearbox.
- 219.03.04** The use of an "open-bottomed" bell-housing that does not completely encircle/enclose the flywheel/clutch assembly is NOT permitted.
- 219.03.05** The removal of material from the bottom of the bell-housing, in order to lower the bell-housing/engine in the car, or for any other purpose, is NOT permitted.
- 219.03.06** The removal of a minimal amount of material from the integral starter-motor housing of an aluminium alloy bell-housing to enable access to the clutch cable is permitted. Blatant / excessive lightening in this area, or actions affecting the structural integrity of the bell-housing are NOT permitted.
- 219.03.07** The bell-housing must NOT be drilled, lightened or modified in any way, other than as detailed above. The presence of a previously required 25mm inspection hole is permitted.

### 219.04 Differentials

- 219.04.01** Differentials may be un-locked, locked, or of the limited-slip design.
- 219.04.02** The use of non-ferrous materials for internal differential components is permitted.
- 219.04.03** Only original specification standard production differential ratios may be used in the ratio range from 3.5:1 to 4.44:1. E.g. the Volvo 3.73:1, BMC 3.90:1, and Ford 4.125:1 are all permitted within this regulation, as are other standard ratios (within the above range) produced by these and other car manufacturers.
- 219.04.04** The removal of material from the differential housing/casing, e.g. excess webbing, is permitted, providing that the safety of the component is NOT compromised.

### 219.05 Prop-shaft Retention Hoop(s) / Tunnel

- 219.05.01** Where the rear of the gearbox tail-shaft (or drive flange for gearboxes without a tail-shaft), is located behind the front edge of the driver's seat, a MINIMUM of 1 steel hoop MUST be fitted around the prop-shaft, designed to retain the prop-shaft in the event of a breakage. The

retention hoop **MUST** be attached to the seat base, chassis rail(s), a chassis cross-member, or the steel cab floor.

- 219.05.02** Where the rear of the gearbox tail-shaft, (or drive flange for gearboxes without a tail-shaft), is located in front of the front edge of the driver's seat, a **MINIMUM** of 2 steel hoops **MUST** be fitted around the prop-shaft, designed to retain the prop-shaft in the event of a breakage. The retention hoops **MUST** be fitted one at each end of the prop-shaft, and be attached to the seat base, chassis rail(s), a chassis cross-member, or the steel cab floor.
- 219.05.03** As an alternative to one or more prop-shaft retention hoops, the use of a prop-shaft retention tunnel is permitted.
- 219.05.04** A prop-shaft retention tunnel along the entire length of the prop-shaft is a permitted alternative to the 2-hoop requirement. Where the rear of the gearbox tail-shaft, (or drive flange for gearboxes without a tail-shaft), is located in front of the front edge of the driver's seat, and only a partial length prop-shaft retention tunnel is fitted on one end, then a **MINIMUM** of 1 steel retention hoop **MUST** also be installed around the opposite end of the prop-shaft.
- 219.05.05** Any folded/curved-up section of the cab floor does **NOT** constitute one of the mandated prop-shaft retention hoops.
- 219.05.06** All prop-shaft retention hoops **MUST** be constructed from a **MINIMUM** material size of 25mm x 3mm flat bar, and be secured either by welding or the use of 8mm **MINIMUM** size high-tensile nuts and bolts.
- 219.05.07** All prop-shaft retention tunnels, where prop-shaft retention hoops are not installed, **MUST** be constructed from 3mm **MINIMUM** thickness steel plate, and be secured to the gearbox, chassis, or steel cab floor either by welding or the use of a **MINIMUM** of four (in number) high tensile 8mm **MINIMUM** size nuts and bolts.
- 219.06 Prop-shaft Protection Cover**
- 219.06.01** In all cases where the rear of the gearbox tail-shaft, (or drive flange for gearboxes without a tail-shaft), is located in front of the front edge of the driver's seat, a metal prop-shaft protection cover **MUST** be installed, designed to prevent the driver's legs/clothing from catching on the rotating prop-shaft. This requirement is in **ADDITION** to the prop-shaft retention hoop requirements above.
- 219.06.02** The prop-shaft protection cover must be constructed from metal sheet with a **MINIMUM** material thickness of 1mm, and be securely fitted to the chassis, floor, gearbox, or retention hoop.
- 219.06.03** The prop-shaft protection cover **MUST** be installed inside/underneath any prop-shaft retention hoop(s) for ease of scrutineering.
- 219.06.04** The prop-shaft protection cover **MUST** extend from the rear of the gearbox to behind or level-with the vertical plane from the front edge of the driver's seat, and **MUST** completely cover the prop-shaft/rotating components.
- 219.06.05** Modification, lightening, drilling or perforation of the prop-shaft protection cover (except for any required mounting-bolt holes) is **NOT** permitted.
- 219.06.06** A prop-shaft retention tunnel, installed between the rear of the gearbox/tail-housing and the front edge of the driver's seat, and constructed from 3mm steel plate, is deemed to satisfy the protection requirements above. An additional prop-shaft protection cover is not required in such cases.

## 220 Batteries & Electrical

### Battery

- 220.01** Any type of conventional lead-acid, gel-filled, or Absorbed Glass Mat (AGM) type battery may be used, in a single or dual configuration subject to the regulations below.
- 220.02** In a single battery configuration, the **MAXIMUM** permitted size of the battery is the "075" standard (dimensions: 245mm x 175mm x 175mm, OR, volumetric equivalent: 7,503 cu. cm).
- 220.03** In a dual battery configuration, a **MAXIMUM** of 2 batteries may be used. The **MAXIMUM** permitted size of each battery in this configuration is the "063" standard (dimensions: 210mm x 175mm x 175mm, OR volumetric equivalent: 6,431 cu.cm.).
- 220.04** In a dual battery configuration, **BOTH** batteries **MUST** be connected and used for powering/running the car.
- 220.05** All acid-filled batteries **MUST** be covered with a rubber or similar anti-corrosive material to prevent the spilling of battery acid.
- 220.06** The terminals of **ALL** battery types **MUST** be covered with a rubber or similar non-conductive material to prevent sparking/short circuiting.
- 220.07** Batteries **MUST** be bolted to the chassis to prevent movement in an impact or roll-over.



- 220.08** Batteries must NOT be located where they may leak acid/fumes on to the driver safety harness.
- 220.09** Batteries must NOT be fitted between the driver's legs.
- 220.10** If fitted outside of the main chassis rails, batteries MUST be positioned next to, or overlapping with, the vertical plane of the outside edge of the main chassis rail; there must be NO gap between that vertical plane and the battery/batteries.

#### **Master Isolator Switch**

- 220.11** A battery isolator switch, in the earth circuit, MUST be fitted to the dashboard of the car at the base of the windscreen in an easily accessible position (from the outside). The On/Off positions of the switch MUST be clearly marked on the dashboard, and the location of the switch MUST be clearly marked on the outside of the car where it can be seen by track marshals.

#### **Isolator Cut-Off Pull-Cord**

- 220.12** A mechanical pull-cord, connected to the master electrical battery isolator switch MUST be installed.
- 220.13** The pull-cord MUST be installed such that when pulled it switches OFF the master electrical isolator switch, and thus stops the engine and fuel-pump from running.
- 220.14** The handle of the pull-cord MUST be...
- Securely mounted to a seat support tube or other appropriate cross-member.
  - Mounted in the rear section of the driver's cab area, behind the driver's seat to the left of the driver.
  - Mounted so that it can be pulled rearwards by a marshal, away from the car, in a front to rear motion.
  - Mounted so that it can be easily pulled through the rear-window aperture in a single movement.
  - Mounted to a bracket of sufficient strength that will not deform or move under load.
  - Mounted at an angle of no more than 45° up from the horizontal.
- 220.15** The pull-cord itself must be fitted in a smooth curve from the handle to the master isolator switch to prevent the cable from binding inside the sheath.
- 220.16** The use of a secondary electrical cut-off switch in place of a mechanical pull-cord is NOT permitted.

## **221 Radiators and Cooling System**

- 221.01** A water-based liquid cooling system MUST be used.
- 221.02** The use of a water coolant additive is permitted, with the following exclusion:  
**221.02.01 Venray (Netherlands) Only** – The use of a water coolant or any water additive is NOT permitted when racing at Raceway Venray. All cars MUST run plain water as the ONLY permitted method of cooling the engine.
- 221.03** Any radiator and associated pipes are permitted.
- 221.04** Any radiator MUST be fitted within the footprint of the main chassis rails, AND forward of the firewall between the engine and driver compartments.
- 221.05** The placement/routing of any cooling system component, liable to contain coolant fluid, in/through the driver's cab area is NOT permitted. E.g. header tanks, pipework.
- 221.06** Cooling systems MUST utilise the original outlets from the engine.
- 221.07** Blocking off the heater hose outlets on the water pump and/or inlet manifold is permitted.
- 221.08** Use of the heater hose outlets on the water pump and/or inlet manifold with a secondary radiator is permitted.
- 221.09** ALL overflow pipes MUST point directly at the ground.
- 221.10** The use of electric cooling fans is permitted.
- 221.11** The use of mechanical cooling fans is permitted.

## **222 Fuel and Fuel System**

### **222.01 Fuel System**

- 222.01.01** Pressurized fuel systems are NOT permitted.

### **222.02 Fuel Tank**

- 222.02.01** Only one fuel tank is permitted.
- 222.02.02** The MAXIMUM permitted fuel tank capacity is 3 gallons (13.64 litres).
- 222.02.03** The fuel tank MUST be constructed of steel with a MINIMUM 2mm wall thickness. The use of an alloy fuel tank is NOT permitted.
- 222.02.04** The filler cap MUST be of a metal threaded screw type.
- 222.02.05** The fuel feed pipe MUST enter the fuel tank at or near the top.
- 222.02.06** The fuel tank MUST have a breather pipe to prevent spillage in case of inversion.
- 222.02.07** The fuel tank breather pipe MUST exit to air on the opposite side of the car to the exhaust system. If the breather pipe passes through the cab area it MUST conform to the fuel line material specifications below.



- 222.02.08** Where a car's fuel tank is fitted behind the driver's seat, and the exhaust system runs outside the main chassis rails, then the breather pipe **MUST** exit to air on the opposite side of the car's centre-line to the exhaust system. If the exhaust system runs under the cab area, and the fuel tank is mounted behind the driver's seat, then the breather pipe **MUST** exit to air outside of the main chassis rails/cab area on the opposite side of the car's centre-line to the exhaust system.
- 222.02.09** A one-way safety valve **MUST** be fitted in the fuel tank breather pipe to prevent fuel spillage, and **MUST** be in full working order. Modification of, or tampering with the one-way safety valve is **NOT** permitted, and such actions, e.g. removal of the internal components, will result in disciplinary action.
- 222.02.10** The one-way safety valve must be fitted in a location easily viewable by an appointed official. E.g. not hidden away underneath the car, or behind bodywork.
- 222.02.11** The fuel tank **MUST** be securely fitted, preferably strapped down within a steel cage, rather than mounted on lugs that are prone to fatigue.
- 222.02.12** If fitted behind the driver's seat, a full firewall **MUST** be installed between the driver's compartment and the fuel tank.
- 222.02.13** If fitted outside of the main chassis rails, the fuel tank **MUST** be positioned next to the chassis rail with **NO** gap between the outside edge of the rail and the inside edge of the tank. One edge of the fuel tank **MUST** be parallel to the main chassis rail when viewed from above. The outer edge of the tank may be a **MAXIMUM** distance of 9in (228mm) from the outside edge of the main chassis rail. The outside edge of the tank **MUST** be a **MINIMUM** distance of 10in (254mm) from the outside edge of the nerf-rail(s).
- 222.02.14** If fitted outside of the main chassis rails, the fuel tank **MUST** be protected from intrusion from **BOTH** the side (e.g. another car's bumper coming under the nerf-rail) **AND** underneath (e.g. on-track debris, or the top of a fence-post). The intrusion protection must be constructed from steel plate (**MINIMUM** 2mm in thickness) or steel tubes (**MINIMUM** specification of 25mm CHS/SHS x 2mm wall thickness), subject to the regulations above regarding the lamination/stacking of plates and bars. Any steel plate used may be a **MAXIMUM** of 3mm in thickness.
- 222.03 Fuel Line**
- 222.03.01** The fuel line and breather pipe **MUST** be constructed of metal pipe, or steel braided fuel hose.
- 222.03.02** The use of plastic pipes, and/or non-steel braided fuel hoses in the construction of fuel lines and/or breather pipe is **NOT** permitted.
- 222.03.03** A fuel shut-off tap **MUST** be fitted in the fuel line
- 222.03.04** The fuel shut-off tap **MUST** be either:
- Positioned within easy reach of the driver
  - OR
  - Remotely operated by means of a steel cable with the handle positioned within easy reach of the driver
- 222.03.05** The fuel shut-off tap **MUST** be operable by the driver when strapped in their seat, and the driver **MUST** be able to demonstrate this when requested by an appointed official.
- 222.03.06** The location of the fuel shut-off tap **MUST** be clearly marked on the outside of the car where it can be seen by track marshals.
- 222.03.07** The use of a fuel pressure regulator is permitted.
- 222.03.08** Consideration should be given during car construction to the routing of the fuel line, keeping it away from hot exhausts, battery terminals, and other components likely to produce heat or a spark.
- 222.04 Fuel**
- 222.04.01** **Type – UK Tracks** – All cars **MUST** use fuel that is freely available from at least 200 roadside service stations in the UK.
- 222.04.02** **Type – Mainland Europe Tracks** – All cars **MUST** use fuel that is freely available from roadside service stations in continental Europe.
- 222.04.03** **Additives – All tracks (unless specified below)** – The **ONLY** fuel additive permitted for use is Millers "CVL".
- 222.04.04** **Additives – Venray (Netherlands) Only** – The use of fuel additives is **NOT** permitted.
- 222.04.05** **Additives – All tracks** – The Millers "CVL Turbo" product is **NOT** permitted for use.
- 222.04.06** **Fuel Samples** – A **MINIMUM** of 0.5-litre (500ml) of fuel **MUST** remain in the car's fuel tank at all times (including at the end of a race), such that the car can be driven under its own power to any inspection/weighing point, and so that a fuel sample may be taken.

**222.05 Fuel Supply**

- 222.05.01 Supply – UK Tracks** – Any promotion or BriSCA F2 Technical Officer has the right to supply a car or cars, prior to the start of a race, with fuel that conforms to one of the following standards, and will supply an approved additive if required:
- BS EN 228 : 2008 – Unleaded
  - BS 7800 : 2006 – Super Unleaded
- 222.05.02 Supply – Mainland Europe Tracks** – Any promotion has the right to supply a car or cars, prior to the start of a race, with fuel that conforms to the local standards and octane ratings available, and will supply an approved additive if required/permitted.
- 222.05.03** Where BriSCA F2 or a promotion exercises the right to supply fuel to a driver for a race or meeting, then if required/requested to do so, the driver **MUST** pay a fee for the fuel to be used **PRIOR** to racing at the meeting or in the individual race, subject to the following:
- Fuel fees are set to cover the cost of the fuel and any additive only, and will be reviewed on a regular basis.
  - The current fee, **WITHOUT** the CVL additive, is £25 for an entire normal format meeting, and £12 for a single race.
  - The current fee, **WITH** the CVL additive, is £35 for an entire normal format meeting, and £17 for a single race.
  - Where a driver suffers early race damage and is unable to compete in more than half his/her scheduled races at an event then an appropriate partial refund may be made at the conclusion of the meeting.
  - Any refusal to pay the fuel fee, or use the fuel provided, will be treated as a refusal of a technical check, resulting in an immediate suspension and a technical disciplinary process being invoked (a process that could lead to a racing ban).
  - Where a driver is required to pay for fuel under this process, then any fuel drained from the car's tank will be returned directly to the driver (a small sample may be taken). The driver is responsible for providing an appropriate container for the drained fuel.

**223 Exhaust System and Silencer – All Engine Types****223.01 Installation/Fitting**

- 223.01.01** The exhaust system **MUST** be fitted outside the main/lower chassis rails and bodywork of the car, unless explicitly permitted below.
- 223.01.02** Where a car has a sufficiently high floor in the driver's compartment it is permitted to fit the exhaust system between the main chassis rails and run it under the cab floor.
- 223.01.03** The exhaust system **MUST** terminate on the same side of the centre-line of the car as the exhaust ports of the engine.
- 223.01.04** The entire exhaust system **MUST** exit the engine and return along the car on the same side of the centreline as it exits the cylinder head.
- 223.01.05** The exhaust must **NOT** cross the centre-line of the car at any time.
- 223.01.06** It is **NOT** permitted for **ANY** part of the exhaust system to extend rearwards beyond the rear face of the roll-cage. For simplicity, the rear face of the roll-cage is defined as the vertical plane from the point at which the rear roll-cage pillars (pillars 3 and 4) meet the top (main) chassis rails.
- 223.01.07** The use of heat wrap on any part of the exhaust system is **NOT** permitted.
- 223.01.08** The single main pipe, connecting to the mandated silencer, and any pipe joining two silencers together (where mandated), must **NOT** extend into/through the silencer(s), such that they cover any of the internal baffling/perforations or alter the performance of the silencer(s).

**223.02 Silencer/Noise**

- 223.02.01** All cars **MUST** be fitted with the approved BriSCA F2 stainless-steel silencer, with only the following exceptions:
- **Lelystad (Netherlands) Only** – All cars **MUST** be fitted with 2 approved BriSCA F2 silencers, OR, one approved large HGS silencer.
  - **Venray (Netherlands) Only** – All cars **MUST** meet a strict **MAXIMUM** 90dB noise limit at all times, measured according to local standards. The use of 2 approved BriSCA F2 silencers, OR, one approved large HGS silencer is permitted in order to conform to the stated noise limit.
- 223.02.02** The approved stainless-steel silencer has the BriSCA F2 name/logo clearly etched in to it. The silencer **MUST** be fitted such that the BriSCA F2 logo can be easily observed by any race official.

- 223.02.03** The approved BriSCA F2 silencer must NOT be modified in any way.
- 223.02.04** Welding is NOT permitted on the silencer unit within 25mm of the silencer box.
- 223.02.05** An exhaust silencer may be failed by a scrutineer or other appointed BriSCA F2 technical official due to one or more of the following factors:
- The absence of the official BriSCA F2 name/logo.
  - The engine sound, when in use, compared to other cars.
  - A significant difference in volume compared to other cars.
  - A distinct ringing or other unusual sound of the silencer casing (indicating an absence of internal wadding/baffling).
  - The observation/suspicion of any modification(s) or tampering.

### 223.03 System Design – Bespoke Manufactured Systems

#### Design

- 223.03.01** The exhaust system MUST be designed and constructed as a “4-into-1” system, where the 4 individual primary header pipes merge in to a single main pipe through a single collector.
- The use of multi-collectors is NOT permitted.
  - The use of a “4-into-2-into-1” design is NOT permitted.
- 223.03.02** The collector MUST be constructed for the sole purpose of merging the four exhaust primary header pipes in to one main pipe, and MUST NOT incorporate any other performance altering features.
- 223.03.03** The single main pipe linking the collector to the mandated standard BriSCA F2 silencer MUST be straight along its entire length. Bends in this pipe are NOT permitted.
- 223.03.04** Three of the four primary header pipes MUST be constructed as single continuous fully welded pipes from the cylinder head flange to their end at the 4-into-1 collector.
- 223.03.05** It is permitted to construct one of the four primary header pipes in two joining parts, either to aid fitment or help prevent cracking of the pipe at the flange (especially on No.1 cylinder).

#### Dimensions

- 223.03.06** All sections of the exhaust system, from the exhaust ports to the collector, and from the collector to the mandated BriSCA F2 silencer, MUST be constructed from tube with a constant, non-varying, internal and external diameter, with the exception of up to a MAXIMUM of 50mm from the join of each primary header pipe to the cylinder head mounting flange
- 223.03.07** Each of the four primary header pipes must NOT exceed a MAXIMUM length of 790mm. This measurement is taken from the face of the cylinder head flange to the termination of the pipe, and is measured along the centreline of the pipe and through the centreline of any bends.
- 223.03.08** The external diameter of the four primary header pipes must NOT exceed a MAXIMUM of 45mm.
- 223.03.09** The external diameter of the single straight main pipe, linking the collector to the mandated standard BriSCA F2 silencer, must NOT exceed a MAXIMUM of 57mm.
- 223.03.10** The collector must NOT exceed a MAXIMUM length of 150mm. This measurement is taken from the swaged primary end to the point where the single straight main pipe starts. [This regulation is illustrated in Technical Diagram 14.](#)

**Technical Diagram 14**

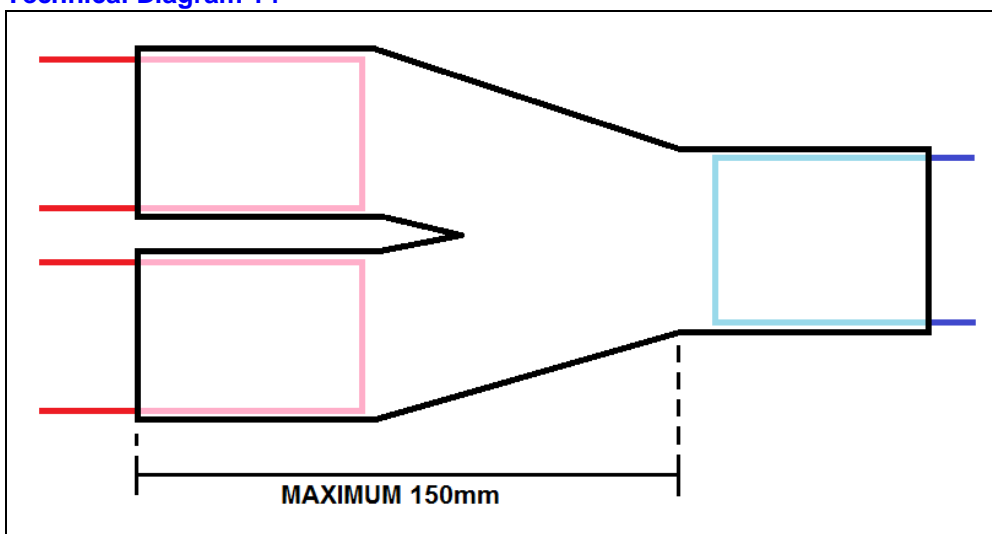

**Materials**

**223.03.11** The exhaust system **MUST** be manufactured from mild steel tubing, or 304 stainless steel tubing.

**223.03.12** The use of paint to provide a protective coating is permitted.

**223.03.13** The use of ANY coating, other than paint as detailed above, is **NOT** permitted.

**Modifications**

**223.03.14** Additional exhaust attachments, tail pipes, and performance altering devices are **NOT** permitted.

**223.03.15** The re-flanging and/or modification of existing Pinto and Duratec based systems for fitment to the Zetec engine is permitted, but any such system **MUST** comply fully with the above regulations.

**223.04 System Design – Zetec Standard Production-Based Systems**

**223.04.01** The standard tubular Ford Focus manifold, as fitted to the permitted 2.0-litre Zetec engine types detailed elsewhere in these regulations, is permitted as an alternative to a bespoke manufactured system.

**223.04.02** The standard Ford Focus manifold must **NOT** be modified internally or externally in any way.

**223.04.03** Mounting the connecting down-pipe under the top (main) chassis rail is permitted.

**223.04.04** The rear-most end of the mandated standard BriSCA F2 silencer must **NOT** pass beyond the vertical plane taken from the rear face of the rear axle half-shaft tubes.

**223.04.05** A **MAXIMUM** of TWO bends are permitted in the single pipe only (connected to the standard Ford Focus manifold) to allow the system to return to the rear of the car.

**223.04.06** A system based on the standard manifold **MUST** conform to all specifications, including but not limited to lengths, diameters, and costs, as detailed for manufactured systems.

**223.05 Purchase Price Cap**

**223.05.01** The purchase value of the complete exhaust system (excluding the standard BriSCA F2 silencer) must **NOT** exceed a **MAXIMUM** of £390 (inclusive of VAT), and this **MUST** be freely available to ALL drivers.

**~~224~~ — NO LONGER APPLICABLE****225 Fire Extinguishers**

**225.01** It is permitted to carry a hand-held fire extinguisher, or have a plumbed-in fire suppressant system installed, in the car.

**225.02** Hand-held fire extinguishers **MUST** be no larger than 1Kg (2.2lbs) in capacity, include a gauge, and contain either dry powder or CO<sub>2</sub> gas. BCF extinguishers (old-style green) are **NOT** permitted.

**225.03** The fire extinguisher or activation knob **MUST** be within easy reach of the driver when strapped in the seat, and mounted below shoulder height.

**225.04** Hand-held fire extinguishers **MUST** be securely mounted, e.g. within a vertical steel tube, with a spring retainer catch to hold it in.

**225.05** Details of the transporter vehicle fire extinguisher requirements can be found in the ORCi Safety Specifications detailed separately in these regulations.

**226 Aerofoils/Spoilers/Wings****226.01 General**

**226.01.01** The use of an aerofoil, spoiler, or wing (subsequently referred to in these regulations using the generic term “wing”), on or over the cab, is optional. Only one such device may be used at any one time.

**226.01.02** Any wing **MUST** conform to one of the three specifications below:

- Sectional wing
- Folded wing
- Spoiler Wing (commonly referred to as a “Superstox” wing)

**226.01.03** The use of any wing on the front, or any other part of the car is **NOT** permitted.

**226.01.04** Any wing **MUST** be mounted centrally on the car when viewed from the front/rear.

**226.01.05** Any wing **MUST** consist of a single-deck/single-layer centre-section **ONLY**.

**226.01.06** The use of multi-deck wings is **NOT** permitted.

**226.01.07** The joining together of multiple level decks is **NOT** permitted.

**226.01.08** A **MAXIMUM** of 2 side-plates are permitted in any wing construction/design: one on the left side/end, and one on the right side/end.

- 226.01.09** The use of non-rectangular side-plates is permitted.  
**226.01.10** Side-plates **MUST** be vertical when viewed from the front or the rear of the car.

## **226.02 Definitions**

- 226.02.01 Sectional Wing** – A sectional wing design is made up of a single main body centre-section, with two attached side-plates, one on the left side of the car, one on the right side.  
**226.02.02 Folded Wing** – A folded wing design is made up of a single sheet of metal, or sheet metal giving the appearance of being folded from a single sheet, formed in to a stretched-out “N” shape, mounted to a supporting frame.  
**226.02.03 Spoiler Wing** – A spoiler wing design is made up of a single wide but shallow main body centre-section, with two attached side-plates, one on the left side of the car, one on the right side.

## **226.03 Design and Dimensions**

### **Sectional Wing**

- 226.03.01** The **MAXIMUM** permitted body centre-section size of a sectional wing is 44in x 44in (1117mm x 1117mm).  
**226.03.02** Side Plates **MUST** have 4 sides.  
**226.03.03** The two opposing long sides of each side-plate must be **NO** longer than a **MAXIMUM** of 48-inches (1219mm) each in length.  
**226.03.04** The two opposing long sides of each side-plate must run from front to rear (they need not be parallel to the ground).  
**226.03.05** The two opposing short sides of each side-plate must be **NO** longer than a **MAXIMUM** of 24-inches (610mm) each in length.  
**226.03.06** The two opposing short sides of each side-plate must run top to bottom (they need not be vertical).  
**226.03.07** The length of the diagonal measurements (between opposing corners) of each side-plate must be **NO** longer than a **MAXIMUM** of 62in (1575mm).

### **Folded Wing**

- 226.03.08** The **MAXIMUM** permitted body centre-section size of a folded wing is 44in x 44in (1117mm x 1117mm).  
**226.03.09** Measurements for the centre section in a folded wing design are taken from the point at which the centre-section plane intersects with the two vertical side-plate planes.  
**226.03.10** The distance from the top of the higher side-plate to the bottom of the lower side-plate, following the profile of a folded wing, must be **NO** longer than a **MAXIMUM** of 92in (2337mm) – (The equivalent of 2 side-plates at 24in each, plus a centre section at 44in).  
**226.03.11** Side Plates **MUST** have 4 sides.  
**226.03.12** Measurements for the higher side-plate in a single-panel design are taken from the top most point (including any curve of the end of the plate) to the point at which the vertical side-plate plane intersects with the (usually angled) centre-section plane.  
**226.03.13** Measurements for the lower side-plate in a single-panel design are taken from the bottom most point (including any curve of the end of the plate) to the point at which the vertical side-plate plane intersects with the (usually angled) centre-section plane.  
**226.03.14** The two opposing long sides of each side-plate must be **NO** longer than a **MAXIMUM** of 48-inches (1219mm) each in length.  
**226.03.15** The two opposing long sides of each side-plate must run from front to rear (they need not be parallel to the ground).  
**226.03.16** The two opposing short sides of each side-plate must be **NO** longer than a **MAXIMUM** of 24-inches (610mm) each in length.  
**226.03.17** The two opposing short sides of each side-plate must run top to bottom (they need not be vertical).  
**226.03.18** The length of the diagonal measurements (between opposing corners) of each side-plate must be **NO** longer than a **MAXIMUM** of 62in (1575mm).

### **Spoiler Wing**

- 226.03.19** The **MAXIMUM** permitted body centre-section size of a spoiler wing is 48in/1219mm (transverse width) x 18in/457mm (longitudinal length).  
**226.03.20** The **MAXIMUM** permitted side plate size is 26in x 12in (660mm x 305mm) (length x height). The entire side-plate **MUST** fit within a rectangular box with these dimensions.

## **226.04 Mounting – General**

### **Sectional and Folded Wings**

- 226.04.01** Sectional and Folded wings **MUST** be mounted above the cab **ONLY**, and adhere to the over-cab mounting regulations below.

**226.04.02** Sectional and folded wings (including but not limited to their body, side-plates and mounting brackets) are NOT permitted to extend rearwards beyond the vertical plane of the rearmost face of the rear bumper.

#### **Spoiler Wing**

**226.04.03** A spoiler wing may be mounted either above the cab, or behind the cab, and MUST adhere to the relevant regulations below.

**226.04.04** A spoiler wing (including but not limited to its body, side-plates and mounting brackets) is permitted to extend up to a MAXIMUM of 300mm behind the vertical plane of the rearmost face of the rear bumper.

**226.04.05** Where ANY part of a spoiler wing (including but not limited to its body and side-plates) is located forward of the plane of the middle roll-cage pillar, then the wing is classified as over-cab mounted and must conform to the over-cab regulations below.

**226.04.06** Where the entire spoiler wing (including but not limited to its body and side-plates) is located rearward of the plane of the middle roll-cage pillar then the wing is classified as rear mounted and must conform to the rear regulations below.

#### **226.05 Mounting – Over-Cab**

**226.05.01** ANY wing (including but not limited to its body and side-plates) mounted over the cab MUST be mounted with at least a MINIMUM clearance of 1in (25mm) between the roofline and the wing body/side-plates at ALL points.

**226.05.02** In practice, any wing MUST be mounted high enough above the roof of the cab such that a tube/pole/bar, 1in (25mm) diameter/square in size, in a horizontal orientation is able to pass below both the side plates and the body, and above the roll cage roof plate along the entire length of any overlap between the wing and the cab roof. [This regulation is illustrated in Technical Diagram 15.](#)

**Technical Diagram 15**

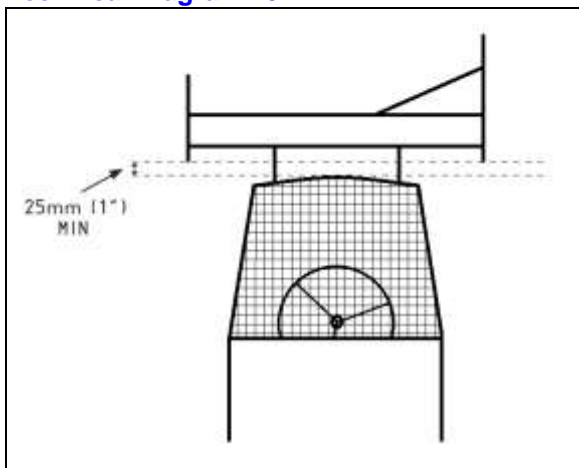

#### **226.06 Mounting – Rear (Spoiler Wings Only)**

**226.06.01** The wing (including but not limited to its body, side-plates and mounts) must NOT overlap with the driver's entry/exit window on either side of the car at any point. This is the area described by the front and middle roll-cage pillars, side bar, and longitudinal roof bar. Any panel-work that may cover these structural components is discounted for the purpose of this check.

**226.06.02** In practice, the wing MUST be mounted such that a straight-edge in a transverse horizontal orientation, can pass through the driver's entry/exit window on both sides of the car AND butt up to all points of the middle roll-cage pillars, and longitudinal roof bars without contacting any part of the wing. Panel-work covering these structural components is discounted for the purpose of this check.

## **227 Transponders**

**227.01** All cars MUST be fitted with a working transponder for electronic lap-scoring.

**227.02** The permitted transponders are:

- MyLaps/AMB – Tran-X 260 DP (Direct-Powered)
- MyLaps/AMB – Tran-X 260 (Rechargeable)
- MyLaps/AMB – Tran-X 160 DP (Direct-Powered)\*\*

- MyLaps/AMB – Tran-X 160 (Rechargeable)\*\*
- MyLaps – X2 Car Transponder (Rechargeable)
- MyLaps – X2 Car Transponder (Direct-Powered)
- MyLaps – TR2 Car Transponder (Rechargeable)
- MyLaps – TR2 Car Transponder (Direct-Powered)

\*\* not recommended, see Note2 below

**Note1:** The subscription for the latest X2/TR2 range of transponders MUST be activated, and the transponder enabled before it can be used on track.

**Note2:** Upgraded track systems no longer work with the X2/TR2 Kart and MX range of transponders (which are not permitted under these regulations) – a function controlled by MyLaps, not ORCi tracks. BriSCA F2 cannot guarantee how much longer the older original, non-subscription, yellow Tran-X 160 and Tran-X 160 DP kart transponders may continue to work for (a use not approved or supported by MyLaps for car-based formulas), and drivers should bear this in mind when purchasing a transponder.

- 227.03** The transponder MUST be securely fitted, and working, at all times when the car is on the track or being scrutineered. Care should be taken with rechargeable units to ensure they are securely fitted to the car and will not come loose in an impact.
- 227.04** The transponder MUST be securely mounted a MINIMUM of 1800mm (1.8m) back from the front bumper (measured to the centre of the transponder signal face that points to the ground), and approximately 450mm from the ground. Care should be taken to ensure a clear line of signal from the transponder to the ground.
- 227.05** The transponder MUST be mounted such that it points vertically downward, or rearward. Angling the transponder such that it points forward from the vertical is NOT permitted.
- 227.06** Transponders may be sold/transferred at any time; however, the driver MUST inform the Licencing Officer and complete a Transfer Form.
- 227.07** Results will NOT be credited to a driver if their transponder fails to operate from the start of the meeting.
- 227.08** Transponders are available from MYLAPS Sports Timing ([www.mylaps.com](http://www.mylaps.com)) and HS Sports ([www.hssports.co.uk](http://www.hssports.co.uk)).

## 228 Driver/Car Identification

- 228.01** The driver's assigned racing number (as indicated on their licence) MUST be displayed on both sides of the car, and on both sides of any roof fin or aerofoil/wing.
- 228.02** The driver's number MUST be black on a white background, in strokes of 1in (25mm) MINIMUM, to a MINIMUM height of 9in (228mm).
- 228.03** The driver's name MUST be displayed in letters at least 3in (76mm) tall on the off-side (right) of the aerofoil (or car body-panels if no aerofoil is fitted) where it can be CLEARLY seen by the spectators.
- 228.04** Sponsor names and logos may appear on the car, but they must NOT interfere with the numbering or driver's name.

## 229 Grading Colours/Roof Painting/Lights

**229.01** The following official championship winning roof/roll-cage colours apply:

- |                                     |   |
|-------------------------------------|---|
| • World Champion                    | Gold  |
| • National Series Champion          | Silver  |
| • British Champion                  | Black/White chequered   |
| • European Champion                 | Red/Yellow chequered  |
| • World of Shale Champion           | Two Gold stripes, 100mm wide                                  |
| • Gala Champion                     | Red/White chequered   |
| • Scottish Champion                 | St. Andrew's Cross/Saltire (Blue with a white diagonal cross) |
| • English Open Champion             | St. George's Cross (White with a red centred cross)           |
| • UK Open Champion                  | Union Flag  |
| • World Cup Champion (NL)           | One Gold stripe, 100mm wide                                   |
| • F2 Supercup Champion (NL)         | Orange/White chequered  |
| • <b>Dutch Open Champion (NL)</b>   | <b>Netherlands Flag</b>                                       |
| • <b>Euromaster (NL)</b>            | <b>Yellow/Green chequered</b>                                 |
| • <b>Irish Open Champion (NI)</b>   | <b>Green/White chequered</b>                                  |
| • <b>Irish Closed Champion (NI)</b> | <b>Green</b>  |

**229.02** The following official grading roof/roll-cage colours apply:

- |                         |                |
|-------------------------|----------------|
| • Superstar/Star grades | "Mail-box" Red |
| • 'A' grade             | Light Blue     |



- 'B' grade Yellow
  - 'C' grade White
  - Novice White, with a 75mm wide Black Cross on the rear of the car
- 229.03** The whole of any wing, if fitted, **MUST** be painted/coloured in the driver's official grading/championship winning colour with the exception of the driver's race number which **MUST** be black on white (see Car Identification regulations above).
- 229.04** The whole of the top surface of the roof plate on all cars **MUST** be painted/coloured in the driver's official grading/championship winning colour (even if the remainder of the roll-cage above the waistline is a neutral colour). A **MAXIMUM** gap of 1in (25mm) will be permitted between the required grading colour section and a vertical straight-edge butted up against the outside edges of the roof/roll-cage.
- 229.05** The roll-cage, and "ear" panels (from the waistline up) of all cars **MUST** be painted/coloured in:
- The driver's official grading/championship colour
  - OR
  - A neutral colour (i.e. NOT one of the grading colours listed above)
- 229.06** The use of ANY shade of grey, silver, or gold for the roll-cage and/or "ear" panels above the waistline of the car is **NOT** permitted, other than by the respective champion as detailed above.
- 229.07** Superstar graded drivers **MUST** fit at least one flashing amber roof light in working order, with sufficient power to be clearly visible by the crowd. The flashing light(s) **MUST** be switched on and operational during racing.
- 229.08** External lights, flashing or otherwise (with the exception of Superstar graded lights), are **NOT** permitted.
- 229.09** Any driver appearing with the wrong roof colour, or without the required flashing superstar lights, will be penalised in accordance with the Technical Infringement Penalties section of these regulations until the issue is rectified to the satisfaction of the Steward/Scrutineer/Clerk-of-the-Course/BriSCA-Official.

## 230 Engines – General Regulations For ALL Engines

### Permitted Engines

- 230.01** The following engines are permitted for use by ALL drivers, subject to the individual specifications below:
- 230.01.01** The **Ford 2.0-litre SOHC NE** type engine (commonly referred to as the 2.0-litre Pinto). This engine has a nominal bore of 90.84mm and a stroke of 76.95mm.
- 230.01.02** The **Ford 2.0-litre 16v Zetec** engine (UK specification) in its 136PS or lower forms (commonly known as the "black-top" engine). This engine has a nominal bore of 84.80mm and a stroke of 88.00mm.
- 230.02** The following engine is permitted for use, **ONLY** by drivers who have used it regularly prior to the **2023** season. BriSCA F2 maintains the list of authorised drivers. Any driver not already using this engine variant is **NOT** permitted to commence its use.
- 230.02.01** The **Ford 1.8-litre Duratec** engine (Engine Type 1.8L (M14)). This engine has a nominal bore of 83mm and a stroke of 83.10mm.  
The regulations for this engine are not included in these "Car Construction Regulations" but are available separately to officials and the last remaining driver authorised to use this engine.

### Engine Mounting

- 230.03** The engine **MUST** be mounted longitudinally in the chassis.
- 230.04** The engine **MUST** be mounted in an upright position, as fitted to the vehicle of origin.
- 230.05** The engine **MUST** be mounted centrally between the main chassis rails such that the rotational centre-line of the crankshaft sits along the centre-line of the car, **subject to the tolerance stated below**.
- 230.06** The **MAXIMUM** permitted tolerance from the rotational centre of the crankshaft to the centre-line of the car is 25mm.
- 230.06.01** The transverse position of the centre-line of the chassis is taken as the perpendicular plane to a transverse straight-edge placed across the main chassis rails, at the mid-point between those two chassis rails (Plane A in [Technical Diagram 16](#)).
- 230.06.02** The transverse position of the crankshaft front-pulley securing bolt is taken as the perpendicular plane to a transverse straight-edge placed across the main chassis rails, when the plane passes through the rotational centre of the bolt (Plane B in [Technical Diagram 16](#)).
- 230.06.03** Method 1 – The central fitment measurement is taken as the perpendicular distance between the two planes described above (the measurement between Plane A and Plane B in [Technical Diagram 16](#)).
- 230.06.04** Method 1 – A tolerance of a **MAXIMUM** of 25mm is permitted for the distance between the two planes described above. [If the engine is exactly central then it will measure 0mm.]
- 230.06.05** Method 2 – Alternatively, the difference between the two distances from the pulley bolt plane (Plane B in [Technical Diagram 16](#)) to the perpendicular planes at the inner edges of the main



chassis rails (Planes C and D in [Technical Diagram 16](#)) must be no larger than a MAXIMUM tolerance of 50mm. [Halving this figure will give the same central fitment measurement from the centre-line, as described in Method 1.]

- 230.06.06** The perpendicular planes can be determined by the use of straight edges and squares with the chassis in any orientation. Alternatively a plumb-line, spirit-level and tape/rule can be used, however, such tools require the chassis to be exactly level and parallel to the ground.

**Technical Diagram 16**

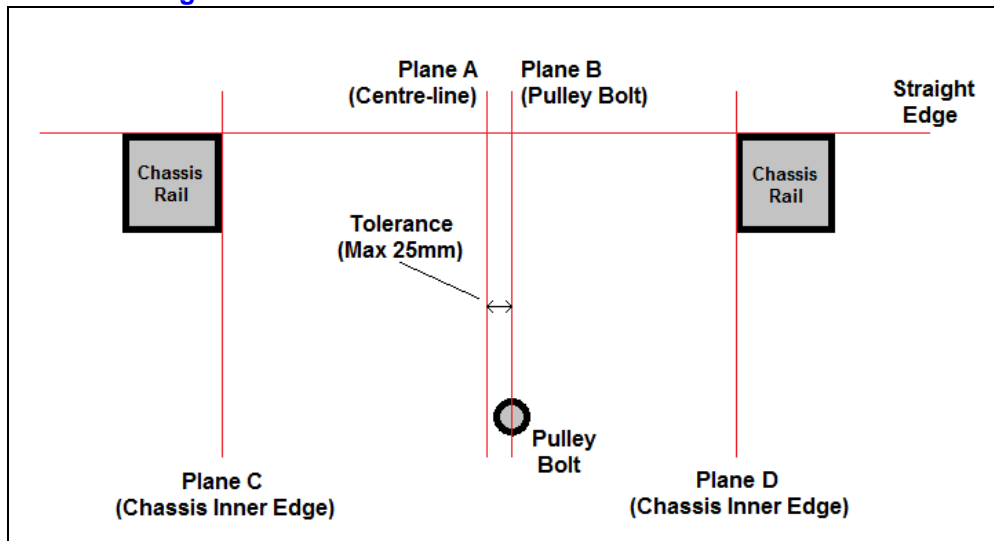

### General Engine Requirements

- 230.07 UK Specification** – Unless otherwise stated, ALL engine parts and components MUST conform to the original UK specification of the permitted engine type in use.
- 230.08 Oil Catch-Tank** – An oil catch tank with a MINIMUM capacity of at least 1-litre MUST be fitted to the car and connected to the engine's breather system.
- 230.09 Throttle Return Springs** – ALL throttle mechanisms MUST be fitted with two effective return springs to reduce the likelihood of a stuck throttle.
- 230.09.01** The return springs MUST be fitted to the throttle mechanism within the engine compartment, NOT the throttle cable, or pedal.
- 230.09.02** The return springs MUST be securely attached to the throttle mechanism and the chassis or fixed engine component. Attaching the return springs with cable ties is NOT permitted.
- 230.09.03** Any integral spring on the throttle cable does NOT count as one of the required return springs (if the cable snaps, this spring has no effect).
- 230.09.04** The small spring attached to the throttle on the carburettor body does NOT count as one of the required return springs.
- 230.10 Performance Parts** – The use of sports or competition specification parts/components is NOT permitted unless explicitly stated.
- 230.11 Turbo/Supercharging** – Turbocharging and/or supercharging is NOT permitted.
- 230.12 Fuel Injection** – Fuel injection is NOT permitted.
- 230.13 Electronic Systems** – Electronic advance/retard and flywheel/crankshaft pickup systems are NOT permitted, unless as a mandatory requirement detailed below – e.g. the required Zetec ECU.
- 230.14 Performance Ignition** – The use of performance ignition systems, including, but not limited to, MSD multi-spark and digital ignition control systems is NOT permitted.
- 230.15 Gauges** – Gauges used to display/monitor engine operating parameters, such as oil pressure, water temperature, and engine speed, are permitted, subject to the following:
- 230.15.01** Tachometers that record the single peak engine speed (so-called “tell-tale” devices) are permitted.
- 230.15.02** Devices that can record and play back parameters/performance recorded over a period of time are NOT permitted.
- 230.16 Restrictor Plate** – BriSCA F2 reserves the right to mandate the use of a control restrictor plate, rev. limiter, ECU, or any alternative method of managing performance, on any of the permitted engine types, should it be deemed necessary in order to maintain competitive parity between them.
- 230.17 Alternator** – The use of a single, standard original specification alternator is permitted.

**230.17.01** The alternator **MUST** be driven from the front of the engine, as per the original road-going vehicles to which the engine type was fitted.

### **230.18 Engine Checking Procedures**

**230.18.01** The scrutineering of engines will be very strict, and on a totally random basis, as the regulations are designed to maintain parity of performance.

**230.18.02** The engine **MUST** be made available at any track for scrutineering.

**230.18.03** Compensation for gaskets and oil will be made, providing the engine is legal (excepting checks for the top three in the World Final).

**230.18.04** Any driver whose engine is sealed or protested **MUST** arrange with BriSCA F2 to have the engine dismantled and checked within 21 days of it being sealed.

**230.18.05** It is the responsibility of the driver to produce his engine for inspection at a convenient place for the involved parties.

**230.18.06** The following people **MUST** be in attendance at the inspection:

- BriSCA F2 appointed Engine Scrutineer
- The Driver's Engineer
- Two witnesses (preferably registered drivers)

**230.18.07** Engines that are required to be stripped for Championship events will be stripped on the day of the event, at the track. A **MAXIMUM** of 3 people from the driver's team (including the driver) may attend the engine inspection.

**230.18.08** It is the responsibility of the driver's team to strip the engine for a championship event, under the direction of the official(s) present. If time constraints require, then an appointed official may assist in the engine stripping process.

## **231 Engines – Ford 2.0-litre SOHC NE (Pinto) Specification**

**231.01 Permitted Engine** – The Ford 2.0-litre SOHC NE type engine (commonly referred to as the 2.0-litre Pinto) is permitted. This engine has a nominal bore of 90.84mm and a stroke of 76.95mm.

### **231.02 General Regulations**

**231.02.01** Unless otherwise stated, **ALL** parts appertaining to the engine **MUST** be standard Ford 2.0-litre SOHC items, as fitted to the original engine type. Production tolerances are permitted.

**231.02.02** The removal or addition of **ANY** material from or to the combustion chamber and/or ports is **NOT** permitted unless specified below.

**231.02.03** Painting of the engine and/or its components, inside and outside, is permitted, except in the combustion chambers and ports, and inlet manifold.

**231.02.04** Internal painting must **NOT** change the surface from matt to smooth.

### **231.03 Engine Block**

**231.03.01** Over-boring the engine block up to a **MAXIMUM** of 1.5mm (0.060in) is permitted.

**231.03.02** Sleeving the cylinder back to 90.84mm and re-boring up to a **MAXIMUM** of 1.5mm (0.060in) oversize is permitted.

**231.03.03** Line-boring of the main bearing housings is permitted.

**231.03.04** Surfacing the block deck is permitted, but pistons must **NOT** protrude above the face of the block at TDC.

**231.03.05** Securing the oil seals and/or core-plugs through the use of grub screws or similar is permitted.

### **231.04 Crankshaft**

**231.04.01** A standard crankshaft **MUST** be used.

**231.04.02** The crankshaft **MUST** weigh at least a **MINIMUM** of 28lbs (12.7Kg).

**231.04.03** Spot machining to achieve crankshaft balance is permitted.

**231.04.04** Tuftriding, shot peening and shot blasting of the crankshaft is permitted.

**231.04.05** Polishing the crankshaft is **NOT** permitted.

**231.04.06** Altering the number of bearings is **NOT** permitted.

**231.04.07** Altering the bearing width is **NOT** permitted.

**231.04.08** The use of narrower bearings of less than **MINIMUM** standard width is **NOT** permitted.

**231.04.09** The use of oversize and/or undersize bearings of standard or heavy-duty material is permitted, but these **MUST** be within the standard range available for engine reconditioning.

**231.04.10** The relieving of oil-way holes on each crank journal is permitted. The modification of all other oil-ways is **NOT** permitted.

**231.04.11** Cross-drilling of crankshafts is **NOT** permitted.

**231.04.12** The original unmodified standard camshaft toothed-belt drive pulley and separating washer, mounted to the crankshaft, **MUST** be used.

- 231.04.13 Water Pump Drive Pulley (Original)** – The original unmodified water pump “V-belt” drive pulley, mounted to the crankshaft is permitted.
- Modification of the original component is NOT permitted.
  - Ford originally produced two sizes of pulley on the Pinto engine – either standard size is permitted.
- 231.04.14 Water Pump Drive Pulley (Replacement)** – Replacement of the standard water pump “V-belt” drive pulley mounted to the crankshaft with a machined/manufactured water pump “V-belt” drive pulley is permitted, subject to the following:
- Any replacement pulley MUST match the type (single V-belt) and size of the original permitted Ford components (either original size is permitted).
  - Any replacement pulley must NOT incorporate the separating washer (which MUST be separately retained).
  - The weight of any replacement pulley MUST measure at least a MINIMUM of 600g.
  - The smaller original pulley has a diameter of 115.55mm
  - The larger original pulley has a diameter of 134.3mm
- 231.04.15** Removal of the separating washer between the camshaft toothed-belt drive pulley and water pump “V-belt” drive pulley mounted on the crankshaft, is NOT permitted.
- 231.04.16** Replacement of the original camshaft toothed-belt drive pulley, mounted on the crankshaft, with a machined/manufactured part is NOT permitted.
- 231.05 Con Rods**
- 231.05.01** Spot machining to achieve con rod balance is permitted using the pad on the big-end cap ONLY.
- 231.05.02** Removal of the bob-weight on the small-end is permitted.
- 231.05.03** [The areas where fettling is permitted are illustrated in Technical Diagram 17.](#)
- 231.05.04** Tuftriding, shot peening and shot blasting of the con rods is permitted.
- 231.05.05** Polishing the con rods is NOT permitted.
- 231.05.06** The fitting of high-tensile bolts is permitted.
- 231.05.07** The use of steel con rods is NOT permitted.

**Technical Diagram 17**

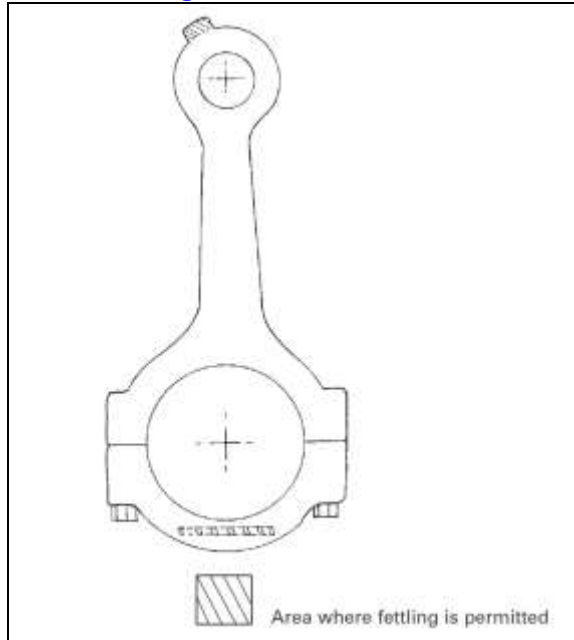

**231.06 Pistons**

- 231.06.01** Pistons MUST be of Ford production type.
- 231.06.02** Powermax pistons are NOT permitted.
- 231.06.03** Forged pistons are NOT permitted.
- 231.06.04** Pistons must NOT be modified in any way, except for balancing or cylinder block resurfacing as detailed below.

- 231.06.05** To achieve balance, the removal of material from any inner surface location is permitted. The removal of material from other locations is NOT permitted.
- 231.06.06** The machining of piston crowns to allow the resurfacing of cylinder blocks is permitted.
- 231.06.07** Piston rings MUST be of standard type.
- 231.06.08** All three piston rings MUST be fitted on each piston.
- 231.06.09** At least one piston MUST retain its original manufacturer's markings.

### 231.07 Cylinder Head

- 231.07.01** Surfacing of the cylinder head face is permitted.
- 231.07.02** Ports and chambers MUST be as originally cast by Ford during the manufacturing process, unless stated below.
- 231.07.03** The first 19mm from the manifold face of the cylinder head in to the inlet and exhaust ports MUST remain as originally cast; fettling is NOT permitted in these areas. This is illustrated in [Technical Diagram 18](#). Fettling of inlet and exhaust ports is only permitted in the area between the valve seat and valve guide, as illustrated in [Technical Diagrams 18 and 19](#).
- 231.07.04** Three-angle valve seats are permitted.
- 231.07.05** Valve seat inserts used to repair damaged heads are permitted. These MUST occupy the EXACT position of the original seat.
- 231.07.06** The addition of metal or any other material to ports and/or chambers is NOT permitted.
- 231.07.07** The strapping of up to a MAXIMUM of 2 out of the 3 camshaft centre main bearing caps is permitted. A MINIMUM of 1 of the camshaft centre main bearing caps MUST remain as standard.
- 231.07.08** The use of a MAXIMUM of 2 threaded inserts, for the sole purpose of repairing broken cylinder head castings for follower-post ball-studs, is permitted.
- 231.07.09** The angle of follower-post ball-studs, relative to the cylinder head, and/or their location, must NOT be altered in any way.
- 231.07.10** Original Ford pattern cylinder-head bolts (early 12-point spline non-stretch type, or late 6-point Torx stretch type) MUST be used (subject to the regulations below). Alternative non-original Ford pattern cylinder head bolts (e.g. socket-cap bolts) are NOT permitted.
- 231.07.11** The shortening of standard cylinder head bolts, use of a spacer washer, or deepening of the threaded hole in the block, in order to achieve the correct cylinder head tightness when surfacing the head/block face is permitted.
- 231.07.12** The use of 2 studs to replace the two centre cylinder-head bolts to facilitate the use of a bolt-on strap over the camshaft centre-post is permitted. The studs MUST be of equal or lower tensile strength than the original Ford cylinder-head bolts. The other 8 cylinder-head bolts MUST be standard (as detailed above).

**Technical Diagram 18**

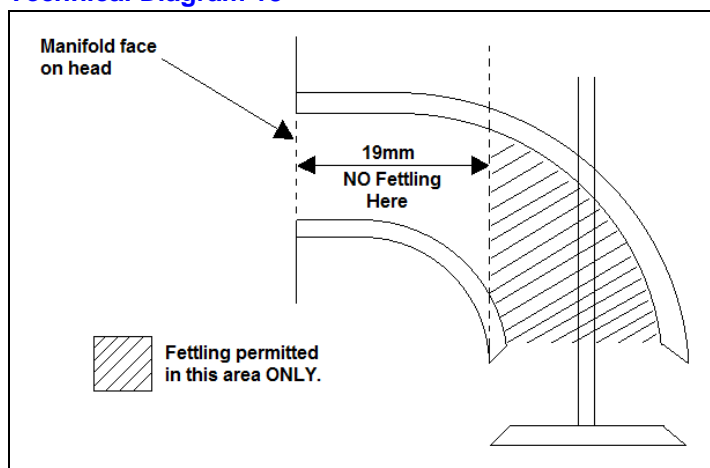

**Technical Diagram 19**

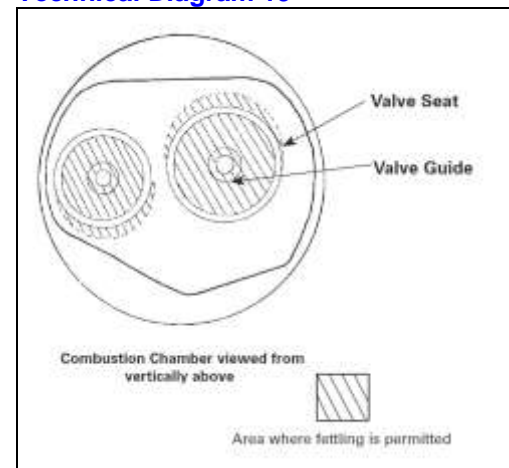

### 231.08 Cylinder Head Valves

- 231.08.01** Valves MUST be of a standard type with head diameters of 42mm +/-0.2mm for the inlet, and 36mm +/-0.2mm for the exhaust.
- 231.08.02** The lightening of valves is NOT permitted.
- 231.08.03** The replacement of valve guides is permitted, but replacements MUST occupy the original positions.
- 231.08.04** The bottom of the valve guide may be trimmed in the area where port fettling is permitted.

**231.08.05** Only eight single valve-springs per engine are permitted. Dual valve-springs are not permitted.

**231.08.06** The use of competition valve-springs is permitted.

**231.08.07** The machining of valve-spring seats is permitted

**231.08.08** The use of shims to achieve correct fitted length is permitted.

**231.08.09** Steel valve-spring caps are permitted.

### **231.09 Camshaft and Followers**

**231.09.01** The camshaft profile is free, but the machining of other engine parts to allow its fitment is NOT permitted.

**231.09.02** Slipper type camshaft followers matching the original standard Ford pattern, made of steel or iron and including those with hardened inserts, are permitted from any manufacturer.

**231.09.03** Roller and/or alloy camshaft followers are NOT permitted.

**231.09.04** The modification of camshaft followers to remove material from the standard component for lightening or any other purpose is NOT permitted.

**231.09.05** Standard camshaft follower retaining springs MUST be used. The use of heavy-duty camshaft follower retaining springs is NOT permitted.

**231.09.06** Standard camshaft bearings MUST be used.

**231.09.07** Centre drilling of standard camshaft bearings to improve lubrication is permitted.

**231.09.08** Replacement ball-studs are permitted, but replacements MUST be made of ferrous material and remain as standard construction, 1.81in in length.

**231.09.09** As a means of repair, up to a MAXIMUM of 3 ball-studs (of the original 8) per engine are permitted to be longer than the standard 1.81in in length.

**231.09.10** A standard 2.0-litre Ford SOHC NE camshaft belt MUST be used.

**231.09.11** The camshaft cover is free, but it must NOT incorporate any water passages.

**231.09.12** The use of a vernier timing wheel is permitted.

**231.09.13** As a means of repairing camshaft thrust groove wear, the machining away and replacement of the worn groove section is permitted. The use of a single centre bolt as a fixing is permitted.

### **231.10 Gaskets and Seals**

**231.10.01 Cylinder Head** – The cylinder head gasket MUST be a Ford original component, or one of the following approved aftermarket replacements. Gaskets MUST retain their original part number markings. Removal of the part number is NOT permitted.

Manufacturer	Part Number	Manufacturer	Part Number
Victor Reinz	61-25985-20	Athena	6816643
Elring	831.182	Glaser	HO3728-00
Payen	AH860		

**231.10.02 Carburettor and Inlet Manifold** – Gaskets MUST be of the original type.

**231.10.03 Other** – All other gaskets not specified above/below are free.

### **231.11 Carburettor**

**231.11.01** The standard Weber 32/36 DGV or Weber 32/36 DGAV carburettor MUST be used.

**231.11.02** The MAXIMUM permitted size of the chokes is 26mm diameter for the smaller, and 27mm diameter for the larger, at any time, whether hot or cold.

**231.11.03** Polishing and/or re-profiling is NOT permitted.

**231.11.04** Modifications to the carburettor body and/or original design are NOT permitted.

**231.11.05** The interchanging of tops from other Weber carburettor models is NOT permitted.

**231.11.06** All gaskets MUST remain standard and original in design and manufacture.

**231.11.07** A single original specification insulator block with two gaskets MUST be fitted between the carburettor and the inlet manifold (the combined total thickness is approximately 5mm depending on the compression of the gaskets). The insulator block and gaskets MUST be of the “single unequal oval hole” design. Use of the rare “twin-hole” RS Mexico insulator block is NOT permitted.

**231.11.08** Changing the main jets, primary and secondary jets, auxiliary venturis, emulsion tubes, and/or accelerator pump jets for alternative standard parts is permitted

**231.11.09** The auxiliary venturis MUST face downwards towards the butterflies.

**231.11.10** Reaming/enlarging the auxiliary venturis is NOT permitted.

**231.11.11** The modification of chokes to open together is permitted. The fitting of replacement spindles with standard screws is permitted.

**231.11.12** The removal of cold-starting devices is permitted. Blanking off the retaining lugs and subsequent holes is also permitted.

- 231.11.13 Enlarging and/or modifying the air and fuel galleries is NOT permitted. Fuel may enter on either side of the float chamber.
- 231.11.14 The modification and/or weighting of floats is NOT permitted. The floats MUST control the fuel flow.
- 231.11.15 The enlargement and/or modification of needle valves is NOT permitted.
- 231.11.16 Needle valves MUST be no larger than a MAXIMUM of size “250”, subject to manufacturing tolerances.
- 231.11.17 The power valve MUST be present and fitted in the base of the fuel bowl. Sealing off the power valve and/or removing the diaphragm is permitted.
- 231.11.18 Trumpets are NOT permitted.
- 231.11.19 The use of a grub-screw or similar device to secure the auxiliary venturis to the carburettor body is permitted.
- 231.11.20 The blanking off and/or modification of top end enrichment devices is permitted.
- 231.11.21 A secondary fixing MUST be used on the fuel feed inlet pipe connection to the carburettor. The secondary fixing MUST be completely independent of the primary fixing for the fuel feed inlet pipe, and is designed to prevent the inlet tube (with the fuel pipe still attached to it) from parting company with the carburettor body.

### 231.12 Inlet Manifold

- 231.12.01 The inlet manifold MUST remain standard.
- 231.12.02 The inlet manifold must NOT be faced to alter the angle of the manifold to carburettor.
- 231.12.03 The gas flow area MUST remain as standard. Material must NOT be added to or removed from the gas flow area.
- 231.12.04 Inlet port matching of the carburettor to the manifold, and/or the manifold to the head is NOT permitted.
- 231.12.05 The fitment of a steel support to stabilise the inlet manifold is permitted, but any fastening must NOT penetrate the manifold runner or plenum.
- 231.12.06 Machining of the inlet manifold is NOT permitted.
- 231.12.07 Welded repairs to cracked manifolds are permitted, but subsequent internal finishing MUST be consistent with the original and NOT be deemed to have affected manifold performance.
- 231.12.08 Blocking off the water circulation hole in the inlet manifold through the use of a putty, sealer, or infill with chemical weld is permitted. Welding or in any way altering the cylinder-head, or welding the hole on the manifold to achieve blocking off is NOT permitted.
- 231.12.09 Painting, coating, or other protection of the inlet manifold is NOT permitted.

### 231.13 Exhaust Manifold

- 231.13.01 The exhaust manifold and system are free, subject to the separately documented Exhaust/Silencer regulations.
- 231.13.02 A silencer MUST be fitted (refer to separately documented Exhaust/Silencer regulations).

### 231.14 Lubrication

#### Sumps

- 231.14.01 The only permitted sumps are as follows:
  - The original steel sump, as fitted to the original engine type. Optional baffling is permitted. Modification/enlargement to increase oil capacity is permitted.
  - The RS2000 alloy sump in standard form only. NO modification is permitted.
- 231.14.02 Dry sumps are NOT permitted.

#### Oil Pump

- 231.14.03 The oil pump must be an original standard specification item.
- 231.14.04 High-capacity oil pumps are NOT permitted.

#### Oil Pickup

- 231.14.05 The modification of oil pickup pipes is permitted.
- 231.14.06 Oil pickup pipes MUST terminate in the sump.

#### Filters

- 231.14.07 Remote oil filters are NOT permitted.
- 231.14.08 Compact oil filters are permitted.
- 231.14.09 The use of a sandwich plate for the fitment of an oil-cooler is permitted.

#### Oil Galleries

- 231.14.10 All oil galleries MUST be unmodified.
- 231.14.11 The relieving of oil-way holes is NOT permitted, with the exception of the crank journals (see crankshaft regulations).

### 231.15 Flywheel And Clutch

- 231.15.01 The flywheel and clutch MUST be standard 2.0-litre components.

- 231.15.02** The total weight of the complete flywheel assembly, including clutch, cover, driven plate, ring-gear and all mounting bolts, but NOT including the thrust bearing, MUST be at least a MINIMUM of 12.31Kg.
- 231.15.03** The total weight of a bare flywheel (which includes the attached ring-gear) MUST be at least a MINIMUM of 6.2Kg.
- 231.15.04** Machining down of the flywheel to the MINIMUM weight (for both the bare flywheel and the complete assembly) is permitted.
- 231.15.05** 1600cc clutch components are NOT permitted.
- 231.15.06** Steel flywheels manufactured by Redline, SRD and Baines have been approved, subject to the above regulations.

## 231.16 Ignition System

### General

- 231.16.01** A conventional single coil and distributor MUST be used.
- 231.16.02** The use/fitting of Lumenition devices is NOT permitted.

### Coil

- 231.16.03** A genuine original oil-filled Ford ignition coil as fitted to the permitted 2.0-litre SOHC NE (Pinto) engine type detailed above may be used.
- 231.16.04** The original Ford part number must NOT be removed, and MUST be clearly visible to the scrutineer or other appointed BriSCA F2 official.
- 231.16.05** A scrutineer or appointed BriSCA F2 technical official reserves the right to require any coil to be replaced until its compliance with these regulations has been confirmed.
- 231.16.06** The ONLY other permitted coil is a Bosch manufactured item with part number 0 221 122 450. The previously mandated Bosch coil with part number 0 221 119 027 may also be used until 1<sup>st</sup> January 2024. (This will be reviewed in 2023)

### Distributor

- 231.16.07** The standard Bosch distributor MUST be used in electronic form only.
- 231.16.08** Modifications to remove vacuum-advance parts, fit competition parts, and/or replace points with electronic ignition are permitted.

### Ignition Amplifier (Black Box)

- 231.16.09** The only permitted ignition amplifiers are the following original and direct replacement units:
- Motorcraft The original unit as fitted by Ford
  - Intermotor Direct replacement
  - Lucas Direct replacement
  - Cambiare Direct replacement
- Other units have not been tested or certified, and cheap copies may not meet original Ford specifications.

### Rev. Limiter

- 231.16.10** The standard BriSCA F2 control rev. limiter and associated wiring loom, designed for the permitted Pinto engine, and supplied by BriSCA F2, MUST be fitted and used at all times. This rev. limiter has an RPM limit set at 7,800 RPM.
- 231.16.11** The use of any other rev. limiter and/or associated wiring loom, other than the BriSCA F2 control components, is NOT permitted.
- 231.16.12** Disconnection of the rev. limiter through mechanical, electronic, or any other means is NOT permitted.
- 231.16.13** A BriSCA F2 control rev. limiter will be assigned to an individual driver, and will be electronically sealed.
- 231.16.14** The BriSCA F2 control rev. limiter must NOT be altered or tampered with by ANY party, other than at the request of BriSCA F2, via the rev. limiter manufacturer.
- 231.16.15** The rev. limiter MUST be located in an easily accessible position, allowing access to it at any and all times by BriSCA F2 representatives and registered scrutineers only.
- 231.16.16** Any modification of the wiring loom, and/or associated components, other than as described below, including but not limited to shortening, lengthening, adding additional wiring, or otherwise altering them, is NOT permitted.
- 231.16.17** Shortening the length of the original supplied wiring (from the unconnected ends), is permitted on the following wires only, as per the **OMEX original official** installation instructions:
- (i) the 5 wires to the Motorcraft (or equivalent) amplifier module, from the 5-way connection plug, and/or
  - (ii) the 6 wires to the distributor (2 wires), coil (2 wires), positive feed (1 wire) and earth (1 wire), from the 6-way connection plug.



Wires/terminals must NOT be removed from the supplied plug connectors, and additional wiring must NOT be added.

**231.16.18** BriSCA F2 reserves the right to swap a driver's rev. limiter for that of another driver, or a replacement item from stock, at ANY time. Failure to comply will result in immediate disciplinary action and a lengthy ban as detailed in the Technical Infringement Penalties section of these regulations.

**231.16.19** BriSCA F2 reserves the right to exchange and/or interrogate ANY ignition components at ANY time. If the rev. limiter has been tampered with in ANY way, the driver will be subject to immediate disciplinary action and a lengthy ban as detailed in the Technical Infringement Penalties section of these regulations.

#### Wiring

**231.16.20** The use of the coil positive feed terminal as a wiring distribution point is NOT permitted.

**231.16.21** In order to minimise electrical interference with the rev. limiter, the ONLY permitted wiring connections to the coil are as follows:

- (i) Pink wire from the 6-way rev. limiter connection plug to the "positive" terminal
- (ii) Yellow wire from the 6-way rev. limiter connection plug to the "negative" terminal
- (iii) HT wire from the centre of the distributor to the "HT" terminal
- (iv) An optional connection from a rev. counter to the "negative" terminal

#### 231.17 Fuel pump

**231.17.01** Any fuel pump is permitted.

#### 231.18 Water Pump

**231.18.01** Electric water pumps are NOT permitted.

**231.18.02** Modification of the water pump is NOT permitted unless stated below.

**231.18.03** Blocking off the heater-hose outlet is permitted.

**231.18.04** The water pump pulley MUST be the original standard type (single V-belt driven) and size. Ford originally produced two sizes of pulley on the Pinto engine – either standard size is permitted.

**231.18.05** Modification of an original water pump pulley is NOT permitted.

**231.18.06** Replacement of the standard water pump pulley with a competition type pulley of the same type and size is permitted.

**231.18.07** The use of an aluminium water pump pulley is permitted.

**231.18.08** Replacement of the standard drive belt with a competition type drive belt is permitted.

**231.18.09** Only a single "V" drive belt is permitted.

**231.18.10** The use of a toothed drive belt is NOT permitted.

#### 231.19 Thermostat Housing

**231.19.01** Modification of the standard thermostat housing is NOT permitted unless stated below.

**231.19.02** The welding of a water temperature gauge outlet to the standard thermostat housing is permitted.

**231.19.03** Blocking off the bleed hose outlet on the standard thermostat housing (as per the original Sierra Pinto component) is permitted.

**231.19.04** Modification of the standard thermostat housing to alter the angle/direction of the outlet pipe is permitted.

**231.19.05** A fabricated replacement thermostat housing is permitted.

**231.19.06** Any fabricated replacement thermostat housing may be made of steel or aluminium alloy.

**231.19.07** Any fabricated replacement thermostat housing MUST only be for the same purpose as the original standard part, i.e. housing a thermostat and directing water to the radiator via an attached pipe/hose.

**231.19.08** Additional functionality (other than a temperature sensor outlet, or bleed hose take-off as per the original Sierra Pinto component) is NOT permitted on a standard or fabricated housing.

**231.19.09** A water temperature gauge outlet in a fabricated thermostat housing is permitted.

**231.19.10** Changing the angle of the outlet pipe (from the original design of the alloy component) in a fabricated thermostat housing, e.g. from upwards to downwards, is permitted.

#### 231.20 Engine Sealing

**231.20.01** An appointed scrutineer may require the engine to be sealed at a race meeting as part of the scrutineering procedure.

**231.20.02** Wire seals will be used to seal engines, and therefore a number of holes MUST be pre-drilled to accept such seals, as detailed below. Where it is not possible to use a wire seal, e.g. with captive bolts, paint will be used as an alternative.

**231.20.03** A hole of 3mm diameter MUST be drilled through the camshaft cover and cylinder head above the No.1 cylinder spark plug.

- 231.20.04** A hole of 3mm diameter **MUST** be drilled through the opposite side of the camshaft cover and cylinder head from the No.1 cylinder spark plug.
- 231.20.05** Additional seals will be fitted as follows:
- The sump will be sealed by removing one sump bolt from each side of the engine and replacing with wire seals.
  - The bell-housing will be sealed to the engine by removing two bell-housing bolts and replacing with wire seals.
  - The carburettor will be sealed to the inlet manifold, and the inlet manifold to the cylinder head, by the use of paint.

## 232 Engines – Ford 1.8-Litre Duratec Specification

*The regulations for this engine have been removed from these “Car Construction Regulations” but are available separately to the last remaining driver authorised to use this engine.*

### **Note: Duratec 2.0-Litre Variant**

- *The 2.0-litre Duratec engine variant, previously used on a trial basis, is NOT permitted for use by ANY driver.*

## 233 Engines – Ford 2.0-Litre 16v Zetec Specification

**233.01 Permitted Engine** – The 136PS or lower form of the Ford 2.0-litre 16v Zetec petrol engine is permitted, in the following specification only. This engine has a nominal bore of 84.80mm and a stroke of 88.00mm.

**233.01.01** The UK specification Ford Zetec 1988cc 16v petrol engine (commonly referred to as the “black-top” engine due to its black plastic camshaft cover) is permitted. (This is additionally referred to as the phase/series 3 engine).

**233.01.02** Only the 136PS or lower forms of the engine with a nominal bore of 84.80mm and stroke of 88.00mm are permitted.

**233.01.03** A new standard un-coded Ford replacement engine to the above and below specification is permitted.

**233.01.04** In ALL cases the engine **MUST** remain in its standard form.

**233.01.05** All other forms of the engine, not specified here, are **NOT** permitted.

**233.01.06** The engine block **MUST** have one of the following codes stamped on it:

- NGB, NGC, NGD (from the Ford Mondeo Mk2 16v 1996-2000)
- EDDB, EDDC, EDDD, EDDF (from the Ford Focus Mk1 16v 1998-2004)
- EBBC, EBBD, EDDB, EDBB (from the Ford Cougar 1998-2001)

The engine code is located on the exhaust side of the cylinder block, i.e. the left side when viewed from the driving position.

**233.01.07** ALL codes and/or ID numbers **MUST** be visible and untouched.

**233.01.08** Production tolerances are permitted, but the total swept volume must **NOT** exceed a **MAXIMUM** of 1989cc.

### **233.02 General Principles**

**233.02.01** The overriding principle of these specifications for the 2.0-litre Zetec engine is that unless it is stated that an action may be taken then a driver **MUST** work on the principle that it cannot.

**233.02.02** The emphasis of these specifications is that the 2.0-litre Zetec engine is an engine that **MUST** remain in its standard form.

**233.02.03** Stringent technical checks **WILL** be carried out on a regular basis, and any contravention of the regulations will result in disciplinary action.

**233.02.04** The engine mount **MUST** be constructed so as to allow the insertion of a crankshaft-locking pin in to the block as part of the technical inspection process.

**233.02.05** Performance of the 2.0-litre Zetec engine in relation to other permitted engines will be closely monitored by all parties within BriSCA F2 – Promoters, drivers, scrutineers, etc.

### **233.03 Component Legality**

**233.03.01** Any component suspected of being illegal, but which the driver claims to be legal according to the regulations, **MUST** be left with the staging promotion until the matter is resolved.

**233.03.02** Failure to leave a suspected illegal component with the staging promotion when requested will automatically render the component illegal, and leave the driver subject to disciplinary action.

**233.03.03** Where a component is suspected of being illegal, it is the responsibility of the driver to prove its legality to BriSCA F2 by way of written proof of the component’s origin.

**233.03.04** Written proof of any suspected illegal component’s origin must be forwarded to BriSCA F2 within 7 days of the initial accusation.

**233.03.05** Failure to provide written proof within the required timeframe will render any suspected component illegal, and will result in an immediate suspension from racing and a referral for disciplinary action.

**233.03.06** With the exception of Championship event post-race scrutineering, BriSCA F2 reserves the right to strip and inspect ANY Zotec engine it sees fit. A fee for parts of up to £300 will be payable to the driver where their engine has been fully stripped (to include the removal of pistons and/or the crank), or up to £150 for a top-end strip (to include the removal of the cylinder head), and has been found to fully comply with the technical specifications in force at the time. In such cases, a nominal contribution for the rebuild labour may also be payable to the driver depending on the extent of the engine strip-down. These fees do NOT apply to the removal of smaller components such as the camshaft cover, or the water pump.

#### ~~233.04 Engine Claim~~

~~**233.04.01** BriSCA F2 reserves the right to purchase any Zotec engine from a driver under these claimer regulations. For the purpose of these regulations the term “engine” relates to the complete cylinder head/engine block assembly only. The following components are EXCLUDED from these claimer regulations:~~

- ~~● Inlet manifold~~
- ~~● Carburetor~~
- ~~● Flywheel~~
- ~~● Clutch~~
- ~~● Starter motor~~
- ~~● Sump~~
- ~~● Exhaust manifold~~
- ~~● ECU~~
- ~~● Wiring loom~~
- ~~● HT leads~~
- ~~● Radiator cooling fan~~
- ~~● Water pump and pipe~~
- ~~● Additional water pump pulleys and bracket~~

~~**233.04.02** Under these claimer regulations the engine MUST be purchased on the day that it was used at an officially sanctioned BriSCA F2 race meeting, and within 30 minutes of the completion of the race meeting.~~

~~**233.04.03** Under these claimer regulations the amount payable to the driver will be fixed at £2,600 +VAT in the UK, and €3,000 +VAT in Mainland Europe. (Prices reflect market rates for donor engines, replacement pistons, consumables, and labour.)~~

~~**233.04.04** A fully registered driver, running a Zotec engine, is also permitted to claim and purchase a Zotec engine from another competitor for the same fixed amount as specified above, and consisting of the same components.~~

~~**233.04.05** Any driver wishing to claim/purchase another competitor's engine MUST have raced in the same meeting as the other party, and MUST be using a Zotec engine in their own car.~~

~~**233.04.06** Any driver wishing to claim/purchase another competitor's engine MUST initiate the process through the staging promoter at the meeting in question. An engine purchase form MUST be completed and a £150 protest fee MUST be lodged with the promoter BEFORE the other party is approached.~~

~~**233.04.07** BriSCA F2 reserves the right to reject a driver's request to claim/purchase if such a request is deemed not to have sound foundation.~~

~~**233.04.08** BriSCA F2 reserves the right to monitor the procedure of engine claims to ensure that it is not misused or abused.~~

~~**Note:** From 1<sup>st</sup> January 2023 the engine purchase/claim section will be removed from the regulations and will no longer apply. The right to protest another driver's engine and have it inspected will, however, remain.~~

#### **233.05 General Specification – Standard Components**

**233.05.01** The expression 'Standard', 'Standard production', or any similar expression is deemed to imply that the part has been manufactured by Ford, or a Ford Motor Company Ltd. authorised sub-contractor, for specific use on a specific model of the permitted engine.

**233.05.02** Only machining and component preparation carried out by Ford Motor Company Ltd., or by a Ford Motor Company Ltd authorised sub-contractor is permitted, unless otherwise specified.

- 233.05.03** Only Ford standard parts, manufactured by Ford Motor Company Ltd. or an authorised sub-contractor, specifically for the permitted 2.0-litre Zetec engine types detailed above are permitted.
- 233.05.04** The interchanging of components from engines not listed in the permitted 2.0-litre Zetec engine types detailed above is NOT permitted.
- 233.05.05** The engine and associated components MUST remain exactly as produced by Ford Motor Company Ltd. unless explicitly detailed in these specifications.
- 233.05.06** BriSCA F2 reserves the right to prohibit the use of specific components introduced as production changes, if in their opinion, they are deemed to have a performance advantage.
- 233.06 General Specification – Materials, Finishing and Reworking**
- 233.06.01** The addition of ANY material, including but not limited to metal, plastic, or composite, by any means, including but not limited to welding, bonding, encapsulation or encasement, to ANY component is NOT permitted.
- 233.06.02** Specific repair of the mounting points of the cylinder block to the transmission and/or chassis is permitted.
- 233.06.03** Casting repairs to other components, not listed above, may be allowed with the prior written approval of BriSCA F2.
- 233.06.04** The use of cleaning processes is permitted, subject to the following;
- The internal/working surface finish MUST remain standard and must NOT be affected by the cleaning process in any way.
  - Industrial surface cleaning of the external surface of engine components, which may result in a polished or roughened finish, is permitted.
- 233.06.05** The modification and/or extension of any production deburring or imperfection removal that took place during initial manufacture is NOT permitted.
- 233.06.06** The decision of BriSCA F2 will be final if any dispute arises regarding the amount of tooling and/or other marks that are evident on any particular component.
- 233.06.07** Protection of exterior surfaces of ferrous components of the complete engine assembly, by paint or similar means, is permitted.
- 233.06.08** Application of ANY protective finish to ANY internal component is NOT permitted.
- 233.06.09** The painting, coating, or application of ANY protective finish to ANY non-ferrous component is NOT permitted. This includes, but is not limited to, the BriSCA/SSCA inlet manifold, and either type of camshaft cover.
- 233.06.10** Any treatment that alters, in any way, the surface finish, hardness, and/or any other property of the original production component is NOT permitted.
- 233.06.11** The removal of any deposit derived from the lubrication and/or combustion process naturally occurring during the running of the engine is permitted.
- 233.06.12** The rework or modification of ANY component is NOT permitted unless explicitly stated in these regulations or unless specifically authorised by BriSCA F2.
- 233.06.13** Any statement regarding a MINIMUM weight or dimension does NOT permit the reworking of components to achieve such measurements unless carried out in accordance with the documented specifications.
- 233.07 General Specification – Fasteners**
- 233.07.01** The use of non-standard replacement fasteners, nuts, bolts, screws, studs and/or washers, which are not connected with or which do not support any moving parts of the engine or its compulsorily retained accessories, is permitted, unless otherwise noted.
- 233.07.02** The use of ARP or similar performance fasteners for the con-rods, flywheel mounting, cylinder head, main bearing caps, camshaft bearing caps, and/or front pulley, is NOT permitted.
- 233.07.03** Freedom granted to any fastener does NOT allow for freedom to move components relative to each other.
- 233.07.04** The use of thread locking compounds is permitted, except on any moving internal engine components.
- 233.07.05** The use of standard assembly lubricants is permitted.
- 233.08 Engine Block**
- 233.08.01** Machining of the cylinder block is NOT permitted, unless allowed by the regulations below.
- 233.08.02** The block height, measured from the lower mating face of the main bearing caps (on the block) to the top face of the cylinder block, MUST meet the Ford specification of a MINIMUM of 212.8mm (8.378in) in height. [This is illustrated in Technical Diagram 20.](#)
- 233.08.03** The use of standard pistons and con-rods, as per these regulations, in conjunction with the above cylinder block measurement, will result in a MINIMUM clearance from the top of the piston to the top face of the cylinder block of 0.46mm (0.018in) with the piston at TDC.

- Any engine where the clearance measures at least a minimum of 0.018in (0.46mm), the Ford specification, will be deemed to be within specification.
- Any engine where the clearance measures less than the minimum 0.018in (0.46mm), as per the Ford specification, will be required to be removed from the car for additional inspection in order to accurately check that it conforms to the original Ford specification above.

- 233.08.04** Enlargement of the cylinder bores, only to accept the BriSCA F2 approved replacement pistons, is permitted.
- 233.08.05** The drilling and tapping of blank casting-lugs on the block, only for use as additional engine mounting points, is permitted.
- 233.08.06** Removal of the extended casting blank below the dipstick, only to facilitate the fitment of a simple flat engine mounting plate, is permitted.
- 233.08.07** Repair of bell-housing mounting bolt locations and engine mounting bolt locations, on the cylinder block, is permitted, but their designed use and/or location must NOT be altered.
- 233.08.08** Line-boring of the crankshaft housings is NOT permitted.
- 233.08.09** Repairing damaged cylinder bores with cylinder liners is NOT permitted.
- 233.08.10** Honing/glaze-busting of the cylinder bores is permitted.
- 233.08.11** Modification of the standard crank-case breather tank, including its removal, is permitted, however, air and/or oil must NOT escape from this area other than through pipework to a catch-tank.
- 233.08.12** The flywheel/crankshaft sensor and its associated housing on the cylinder block must NOT be modified in any way.

**Technical Diagram 20**

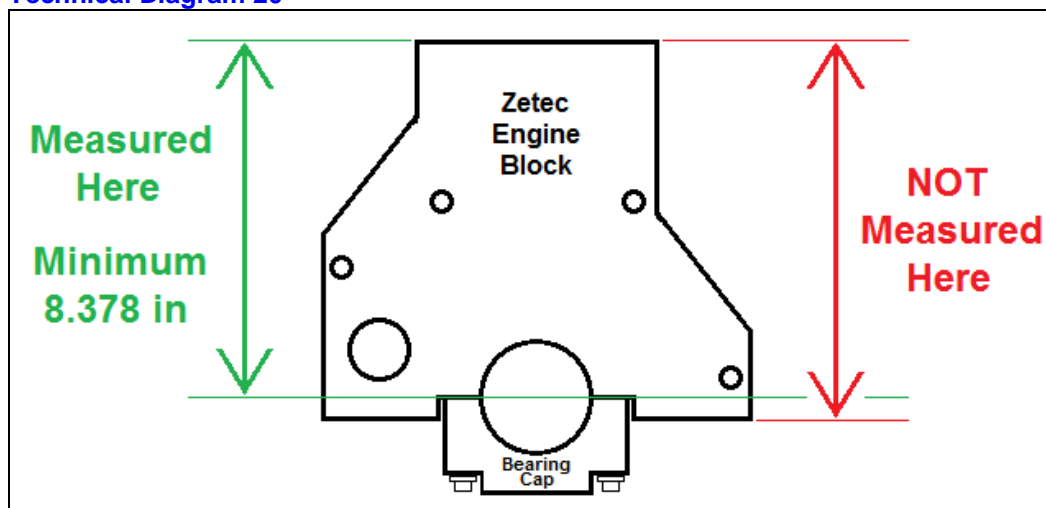

### **233.09 Crankshaft**

- 233.09.01** A standard crankshaft MUST be used, with standard bearing shells unless explicitly detailed below.
- 233.09.02** Post-manufacture balancing of the crankshaft is NOT permitted. The original factory balancing must remain standard.
- 233.09.03** Polishing of the nine crankshaft bearing surfaces is permitted.
- 233.09.04** Polishing of ANY other section(s) of the crankshaft, other than the nine bearing surfaces as detailed above, is NOT permitted.
- 233.09.05** The re-grinding of crankshaft journals for reclaim is permitted, up to a MAXIMUM of a 0.25mm grind from the original standard diameter.
- 233.09.06** Crankshaft journals MUST remain within Ford positional tolerances if a repair re-grind is carried out.
- 233.09.07** The crankshaft pulley/damper unit MUST be retained.
- 233.09.08** Modification of the crankshaft pulley/damper unit is NOT permitted.
- 233.09.09** Use of the crankshaft pulley to drive the water-pump is permitted.
- 233.09.10** Alteration of the number of crankshaft bearings is NOT permitted.
- 233.09.11** The fitment of bearings of less than standard production width is NOT permitted.
- 233.09.12** The use of standard undersize bearings is permitted, up to a MAXIMUM of 0.25mm.

**233.09.13** The following aftermarket bearings only are permitted as replacements for the original Ford components:

<b>Main Bearings</b>		
<b>Manufacturer</b>	<b>Size</b>	<b>Part Number</b>
King	Standard	MB5008SI STD
King	0.25mm	MB5008SI 0.25
KS	Standard	77786600
KS	0.25mm	77786610
Mahle	Standard	014HS20669000
Mahle	0.25mm	014HS20669025

<b>Con-Rod Big-End Bearings</b>		
<b>Manufacturer</b>	<b>Size</b>	<b>Part Number</b>
King	Standard	CR4150SI STD
King	0.25mm	CR4150SI 0.25
KS	Standard	77785600
KS	0.25mm	77785610
Mahle	Standard	014PS20662000
Mahle	0.25mm	014PS20662025

### **233.10 Con-Rods**

**233.10.01** Con-rods MUST be standard.

**233.10.02** The alteration of con-rods, including but not limited to machining, grinding and/or polishing, is NOT permitted.

**233.10.03** Removal of metal material from the con-rod and/or cap is NOT permitted.

**233.10.04** Con-rod bolts MUST be standard Ford production items.

**233.10.05** Aftermarket con-rod bolts are NOT permitted.

**233.10.06** Modification of con-rods to fit bolts is NOT permitted.

### **233.11 Pistons**

**233.11.01** Pistons MUST be standard unmodified production items, OR, approved replacement items designed, supplied and marked by BriSCA F2/SSCA, in their original unmodified form.

#### **Standard Pistons**

**233.11.02** All three piston rings MUST be fitted on each piston, as originally designed/intended.

**233.11.03** Piston rings MUST be standard production components, or, replacement components to Ford Motor Company Ltd. specifications.

**233.11.04** Aftermarket steel piston rings are NOT permitted.

#### **BriSCA F2 Pistons**

**233.11.05** All piston rings, as supplied by BriSCA F2 for the approved replacement piston, MUST be fitted and used in their original unmodified form.

**233.11.06** Piston rings not supplied by BriSCA F2 are NOT permitted.

### **233.12 Cylinder Head**

**233.12.01** The addition, removal, replacement and/or transfer of material on the cylinder head is NOT permitted, unless stated below.

**233.12.02** Line-boring of the camshaft housings is NOT permitted.

**233.12.03** Simple cleaning of the cylinder head, which does not alter the shape of the component in any way, is permitted.

**233.12.04** Minimal material removal from the cylinder head face to correct combustion chamber volume, and/or reclaim head flatness, is permitted.

**233.12.05** The cylinder head MUST achieve at least a MINIMUM thickness of 132.6mm at any and all points. Measurements are taken from the extreme top and bottom faces of the cylinder head and exclude any gaskets. [This is shown in Photo Illustration 01.](#)

**233.12.06** Replacement of the valve guides and/or valve seat inserts is NOT permitted.

**233.12.07** Internal rework of the combustion chamber(s) is NOT permitted.

**233.12.08** The use of high-tensile, competition, and/or ARP cylinder-head bolts is NOT permitted.

**233.12.09** Removal of the unused inlet camshaft sensor, and sealing the resultant hole with a core-plug, is permitted.



Photo Illustration 01



Photo Illustration 02



### 233.13 Cylinder Head Valve Train

- 233.13.01 Modification of valve train components, and or replacement with non-standard parts, is NOT permitted, unless stated below.
- 233.13.02 Modification to alter the thickness of the tappet shim/follower on top of the cam bucket, to achieve the correct valve clearance, is permitted.
- 233.13.03 The shimming and/or packing of valve-springs is NOT permitted.
- 233.13.04 Valves and valve-springs MUST remain standard Ford Motor Company Ltd. manufactured and supplied items, OR, approved replacement items designed, supplied and/or marked by BriSCA F2/SSCA, in their original unmodified form. The use of aftermarket valves and/or valve-springs is NOT permitted.
- 233.13.05 Re-profiling and/or polishing valves is NOT permitted.
- 233.13.06 The original 45-degree valve seat angle (with 90 degree included) MUST be maintained.
- 233.13.07 Standard valve stem seals MUST be retained.

### 233.14 Camshaft and Pulleys

- 233.14.01 The standard production camshafts, as fitted to the permitted 2.0-litre Zetec engine types detailed above, MUST be used.
- 233.14.02 Use of camshafts from the 1.8-litre “Black-Top” Zetec engine is NOT permitted.
- 233.14.03 The interchanging of inlet and exhaust camshafts is NOT permitted. Camshafts are identified by two small casting rings; the rings being located in different positions on the inlet and exhaust camshafts. The identification rings on the inlet camshaft are located separately, one adjacent to inlet valve four, and the other adjacent to inlet valve six. [The inlet camshaft is shown at the bottom in Photo Illustration 02.](#) The identification rings on the exhaust camshaft are both located centrally, adjacent to each other, between cylinders two and three. [The exhaust camshaft is shown at the top in Photo Illustration 02.](#)
- 233.14.04 The use of a camshaft with damaged timing faces is NOT permitted.
- 233.14.05 Modification of the camshafts in any way is NOT permitted, unless explicitly detailed in these regulations.
- 233.14.06 Camshafts MUST be fully manufactured and ground by Ford Motor Company Ltd.
- 233.14.07 The surface finish MUST remain as originally produced. Any other surface finish is NOT permitted.
- 233.14.08 Grinding camshafts from blanks, regrinding camshafts, and/or re-profiling camshafts is NOT permitted.
- 233.14.09 Shot-peening, shot-blasting, surface treatments and/or polishing are NOT permitted.
- 233.14.10 The standard Ford production camshaft drive pulleys MUST be used. [These are shown in Photo Illustration 03.](#)
- 233.14.11 Non-standard, competition, and/or modified drive pulleys are NOT permitted.
- 233.14.12 The timing belt configuration on the permitted Ford Cougar engine (with an additional cam-belt tensioner) MUST remain as standard. Removal of the additional tensioner, and relocation of the remaining one, is NOT permitted.
- 233.14.13 Locking the spring-loaded cam-belt tensioner, or replacing it with a fixed item, is permitted.
- 233.14.14 Any replacement fixed cam-belt tensioner MUST be the same size as the original Ford spring-loaded item.
- 233.14.15 Cam-belt tensioners must be mounted as per the original Ford installation. The use of studs is NOT permitted.



- 233.14.16** Camshaft timing **MUST** remain in the standard Ford position within a tolerance of 0.010" (0.254mm) advance or retard measured on the pistons' position from TDC.
- 233.14.17** The timing of the two camshafts must **NOT** be altered independently of each other. A standard Ford locking/timing bar (nominal thickness 5mm), or aftermarket equivalent, **MUST** be able to simultaneously pass through the slots in the back of the two camshafts when in TDC position. Failure to comply will result in immediate disciplinary action. [The TDC position and camshaft slots are shown in Photo Illustration 04.](#)
- 233.14.18** Locking of timing pulleys to the camshafts through the use of grub screws tapped in to the pulleys and the ends of the camshafts is permitted, subject to the following:
- A **MAXIMUM** of 2 grub screws is permitted per camshaft.
  - The grub screw(s) **MUST** be concealed behind the head of the standard flange-headed bolt used to secure the pulley to the camshaft.
  - The standard flange-headed bolt used to secure the pulley to the camshaft **MUST** be retained.
  - A **MAXIMUM** of 2 tapped holes in each timing pulley are permitted.
  - A **MAXIMUM** of 4 tapped holes in the end of each camshaft are permitted, to allow for the resetting of the timing to the correct position following any permitted skimming of the cylinder head.
- [This is shown in Photo Illustrations 05 and 06.](#)
- 233.14.19** A profile-checking gauge will be used by BriSCA F2 to check that camshafts are standard.

**Photo Illustration 03****Photo Illustration 04****Photo Illustration 05****Photo Illustration 06**

## 233.15 Gaskets and Seals

- 233.15.01 Cylinder Head** – The cylinder head gasket **MUST** be a Ford original component, or one of the following approved aftermarket replacements. Gaskets **MUST** retain their original part number markings. Removal of the part number is **NOT** permitted.

Manufacturer	Part Number	Manufacturer	Part Number
Victor Reinz	61-34340-00 61-34440-00	Goetze (ceased prod.)	30-029870-00 30-028827-00
Elring	123.483 468.860	Glaser	H80058-00 H80422-00
Payen	AE5320 BZ490	Athena	101511-5250
Elwis Royal	0026588		

**233.15.02 Inlet Manifold** – The use of an aftermarket gasket, or silicone-based sealer, to seal the inlet manifold to the cylinder head is permitted.

**233.15.03 Inlet Manifold** – The inlet manifold gasket, or silicone-based sealer, sealing the inlet manifold to the cylinder head, must NOT exceed a MAXIMUM thickness of 5mm.

**233.15.04 Carburettor** – Gaskets MUST be of the original type, as used on the original Ford Pinto application.

**233.15.05 Other** – All other gaskets are free.

### 233.16 Carburettor

**233.16.01** The standard Weber 32/36 DGV or Weber 32/36 DGAV carburettor MUST be used.

**233.16.02** The MAXIMUM permitted size of the chokes is 26mm diameter for the smaller, and 27mm diameter for the larger, at any time, whether hot or cold.

**233.16.03** Polishing and/or re-profiling is NOT permitted.

**233.16.04** Modifications to the carburettor body and/or original design are NOT permitted.

**233.16.05** The interchanging of tops from other Weber carburettor models is NOT permitted.

**233.16.06** All gaskets MUST remain standard and original in design and manufacture.

**233.16.07** A single original specification insulator block with two gaskets, as fitted in the Ford Pinto application, MUST be fitted between the carburettor and the inlet manifold (the combined total thickness is approximately 5mm depending on the compression of the gaskets). The insulator block and gaskets MUST be of the “single unequal oval hole” design. Use of the rare “twin-hole” RS Mexico insulator block is NOT permitted.

**233.16.08** Changing the main jets, primary and secondary jets, auxiliary venturis, emulsion tubes, and/or accelerator pump jets for alternative standard parts is permitted.

**233.16.09** The auxiliary venturis MUST face downwards towards the butterflies.

**233.16.10** Reaming/enlarging the auxiliary venturis is NOT permitted.

**233.16.11** The modification of chokes to open together is permitted. The fitting of replacement spindles with standard screws is permitted.

**233.16.12** The removal of cold-starting devices is permitted. Blanking off the retaining lugs and subsequent holes is also permitted.

**233.16.13** Enlarging and/or modifying the air and fuel galleries is NOT permitted. Fuel may enter on either side of the float chamber.

**233.16.14** The modification and/or weighting of floats is NOT permitted. The floats MUST control the fuel flow.

**233.16.15** The enlargement and/or modification of needle valves is NOT permitted.

**233.16.16** Needle valves MUST be no larger than a MAXIMUM of size “250”, subject to manufacturing tolerances.

**233.16.17** The power valve MUST be present and fitted in the base of the fuel bowl. Sealing off the power valve and/or removing the diaphragm is permitted.

**233.16.18** Trumpets are NOT permitted.

**233.16.19** The use of a grub-screw or similar device to secure the auxiliary venturis to the carburettor body is permitted.

**233.16.20** The blanking off and/or modification of top end enrichment devices is permitted.

**233.16.21** A secondary fixing MUST be used on the fuel feed inlet pipe connection to the carburettor. The secondary fixing MUST be completely independent of the primary fixing for the fuel feed inlet pipe, and is designed to prevent the inlet tube (with the fuel pipe still attached to it) from parting company with the carburettor body.

### 233.17 Inlet Manifold

**233.17.01** The standard BriSCA F2 control inlet manifold, designed for the permitted Zetec engine types, and stamped accordingly, MUST be used.

**233.17.02** The use of any inlet manifold, other than the BriSCA F2 control component, is NOT permitted.

- 233.17.03** Internal modification of the inlet manifold in any way, including but not limited to shot-blasting, is NOT permitted.
- 233.17.04** External modification of the inlet manifold in any way is NOT permitted.
- 233.17.05** The angle of relationship between the carburettor mounting face and the cylinder head mounting face must NOT be altered in any way.
- 233.17.06** Blanking off the brake servo take-off is permitted, but any blanking device must NOT penetrate the manifold runner or plenum.
- 233.17.07** The fitment of a steel support to stabilise the inlet manifold is permitted, but any fastening must NOT penetrate the manifold runner or plenum. The drilling of holes, or other modification of the inlet manifold to facilitate the fitting of a support, is NOT permitted.
- 233.17.08** Welded repairs to cracked manifolds are permitted, but subsequent internal finishing MUST be consistent with the original and NOT be deemed to have affected manifold performance.
- 233.17.09** Painting, coating, or other protection of the inlet manifold is NOT permitted.
- 233.17.10** Repair of the threads, e.g. through the use of heli-coils, for the studs/bolts used to attach the carburettor to the manifold is permitted. The stud/bolt thread holes MUST remain in their original location.

## 233.18 Lubrication

### Sumps

#### General

- 233.18.01 Steel** – Steel sumps are permitted.
- 233.18.02 Aluminium** – The ONLY permitted aluminium sumps are standard Ford components, with permitted modifications, as detailed below. Any other aluminium sump is NOT permitted.
- 233.18.03 Dry** – Dry sumps are NOT permitted.
- 233.18.04 Depth** – The total external depth of the sump MUST measure at least a MINIMUM of 160mm from the lower face of the engine block, where the sump attaches (thus including any gasket), along at least 50% of its length.
- 233.18.05 Baffle Plate** – An original steel baffle plate, as used in the “Silver-Top” engine/sump, may be fitted directly onto the “Black-Top” engine cylinder block by either of the following methods:
- Using original “Silver-Top” main-bearing cap bolts with tube spacers,  
OR
  - Welding 8mm bolts on to the existing “Black-Top” main bearing cap bolts. In this case, one of the bolts is also permitted to support the oil pickup pipe (see below).
- Machining of main bearing bolts is NOT permitted.
- 233.18.06 Starter Motor Fitment** – Modification of the original cast aluminium section of permitted standard Ford sumps (as detailed below) to remove webbing, for the purpose of fitting a starter motor, is permitted. Modification is only permitted in the area directly next to the start motor.
- 233.18.07 Oil Catch-Tank Return** – The inclusion of a fitting in a fabricated steel sump, or the modification of a permitted aluminium sump to include a fitting, only for the purpose of returning oil to the sump from the mandated oil catch-tank, is permitted.

#### Fabricated Steel Sump

- 233.18.08** A fabricated steel sump is permitted.

#### Black-Top Two-Piece Sump

- 233.18.09** The standard two-piece Ford sump, as fitted to the permitted 2.0-litre “Black-Top” Zetec engine types detailed above, is permitted.
- 233.18.10** Replacement of the lower steel component of the sump with a fabricated steel part, to increase oil capacity, is permitted.
- 233.18.11** Modification of the lower steel component of the sump, to increase oil capacity, is permitted.
- 233.18.12** Modification of the original cast aluminium section of the sump is permitted in order to produce an effective sealing sump unit utilising original components from a donor engine that were designed to add strengthening to the block. E.g. to fit a level flange to which a replacement lower steel oil-pan can be fitted.
- The aluminium cast section must NOT be increased in depth or volume.
  - The lower oil-pan section MUST be a steel component, as described above.

#### Silver-Top One-Piece Cast-Aluminum Sump

- 233.18.13** The standard one-piece Ford sump, as fitted to the early “Silver-Top” Zetec engine variants, is permitted.
- 233.18.14** Modification of the sump, to increase oil capacity, or remove part of the cast section, is permitted.

**233.18.15** The first 90mm in depth below the level of the block face, to which the sump is bolted, **MUST** remain as original along the entire length of the sump.

**233.18.16** The use of an aluminium baffle plate is permitted, which **MUST** be welded inside the sump itself.

#### **Sierra CVH Steel Sump**

**233.18.17** A standard 1.8-litre Ford Sierra CVH steel sump is permitted.

**233.18.18** Modification of the sump to fit the Zetec engine is permitted.

#### **Oil Pickup Pipe**

**233.18.18** Replacement or modification of a single bearing cap bolt, to allow support and/or relocation of the oil pickup pipe, is permitted.

**233.18.19** The welding of a stud to a main bearing cap bolt, to support the oil pickup pipe, is permitted.

**233.18.20** Machining of main bearing bolts is **NOT** permitted.

**233.18.21** Modification of the oil pickup pipe is permitted.

#### **Oil Filters**

**233.18.22** Remote oil filters are **NOT** permitted.

**233.18.23** Competition oil filters are **NOT** permitted.

**233.18.24** Replacement of the standard oil filter with a shorter filter is permitted.

**233.18.25** Any shorter oil filter **MUST** be identically located to the standard oil filter.

**233.18.26** Any shorter oil filter **MUST** be a commonly available non-competition item.

#### **Oil Pump**

**233.18.27** Modification of the standard Ford oil pump and/or front cover, including but not limited to the plunger, pressure valve and/or spring, is **NOT** permitted.

#### **Oil Coolers**

**233.18.28** The use of an oil-cooler is **NOT** permitted.

#### **Oil Spray Jets**

**233.18.29** Removal or modification of the four standard oil spray jets in the cylinder block is **NOT** permitted.

#### **Dipstick**

**233.18.30** The standard oil dipstick and tube **MUST** be fitted to the cylinder block.

**233.18.31** Modification of the standard oil dipstick and/or tube to fit the sump, dependant on the sump being used, is permitted.

### **233.19 Flywheel And Clutch**

#### **Flywheel**

**233.19.01** The standard BriSCA F2 control flywheel, designed for the permitted Zetec engine types, with a registered serial number, **MUST** be used.

**233.19.02** Modifications to the BriSCA F2 control flywheel are **NOT** permitted.

**233.19.03** The use of any flywheel, other than the BriSCA F2 control component, is **NOT** permitted.

**233.19.04** Bolts to mount the pressure plate to the flywheel are free, but they **MUST** be of a ferrous material.

**233.19.05** The use of shorter bolts, from the automatic engine/transmission variant, for mounting the flywheel to the crankshaft is **NOT** permitted.

#### **Ring-Gear**

**233.19.06** The standard 2.0-litre Ford Pinto flywheel ring-gear is permitted.

**233.19.07** The standard flywheel ring-gear for the permitted Zetec engine types, as detailed above, is permitted.

**233.19.08** The use of any other flywheel ring-gear, other than those detailed above, is **NOT** permitted.

#### **Clutch**

**233.19.09** The clutch **MUST** be a standard Ford Pinto based 8.5in component.

**233.19.10** Spot balancing of the clutch is permitted within standard industry practice. Wholesale removal of material to lighten the clutch is **NOT** permitted.

#### **Weights**

**233.19.11** The flywheel, ring-gear and mounting bolts combined **MUST** weigh at least a **MINIMUM** of 6.2Kg. This **MINIMUM** weight excludes the clutch and clutch fixing bolts.

**233.19.12** The clutch pressure plate unit (incorporating the cover, diaphragm spring and pressure plate), on its own (excluding the clutch disk and mounting bolts), **MUST** weigh at least a **MINIMUM** of 4.0Kg.

#### **Starter Motor**

**233.19.13** A standard Ford Pinto based starter motor, or a hi-torque competition replacement, **MUST** be fitted and used.

## 233.20 Ignition System, Electrical, and Engine Control Unit (ECU)

### Crankshaft Sensor

- 233.20.01 A Ford crankshaft speed sensor MUST be fitted to the standard manual sensor housing, and connected to the ECU as the ONLY means of ignition timing.
- 233.20.02 The flywheel/crankshaft sensor and its associated housing on the cylinder block must NOT be modified in any way.
- 233.20.03 The crankshaft speed sensor MUST have an air gap between it and the flywheel measuring between a MINIMUM of 0.1mm, and a MAXIMUM of 0.8mm.

### ECU and Wiring Loom

- 233.20.04 A standard BriSCA F2 control ECU and wiring loom, designed for the permitted Zetec engine, and supplied by BriSCA F2, MUST be used. This ECU has an RPM limit set at 7,800 RPM.
- 233.20.05 The use of any other ECU and/or wiring loom, other than the BriSCA F2 control components, is NOT permitted.
- 233.20.06 A BriSCA F2 control ECU will be assigned to an individual driver, and will be electronically sealed.
- 233.20.07 The BriSCA F2 control ECU must NOT be altered or tampered with by ANY party, other than at the request of BriSCA F2, via the ECU manufacturer.
- 233.20.08 The ECU diagnostic connector MUST be located in an easily accessible position allowing access to it at any and all times by BriSCA F2 representatives and registered scrutineers only.
- 233.20.09 Modification of the BriSCA F2 control wiring loom, including but not limited to shortening, lengthening, or otherwise altering it, is NOT permitted, unless explicitly stated below.
- 233.20.10 It is permitted to shorten and add appropriate terminal connectors to the following five unconnected wire ends supplied on the original wiring loom:
  - Two earth wires connected to the large plug
  - Live feed wire connected to the large plug, marked “Coil”
  - Live feed wire connected to the large plug, marked “ECU”
  - Wire connected to the large plug, marked “Tacho”

Shortening wires and connecting terminals is ONLY permitted from the unconnected end of each of the five wires listed above. It is NOT permitted to remove wires from the pre-wired plugs, shorten original wiring that is supplied connected to plugs at both ends, or add additional wiring.

- 233.20.11 The following minor repairs to the control wiring loom are permitted:
  - Replacement of a broken crank-sensor plug with a standard original or aftermarket equivalent. This MUST be wired the same as the original control loom plug.
  - Joining/splicing one or more broken wires back together. The wholesale replacement of one or more lengths of wire within the control loom is NOT permitted.
 Any other repairs MUST be arranged through BriSCA F2 with the ECU manufacturer, or be given prior approval BEFORE being carried out (contact the Chief Technical Consultant).

### Ignition Coil

- 233.20.12 A genuine Ford ignition coil as fitted to the permitted 2.0-litre Zetec engine types detailed above, or a direct aftermarket replacement ignition coil with a part number cross-referencing directly to the original Ford item, MUST be used.
- 233.20.13 Repositioning of the coil unit is permitted.

### Ignition Leads

- 233.20.14 Any HT leads to the sparking plugs are permitted – E.g. the longer leads as fitted to the Ford Cougar V6.

#### **Note for 2024**

- ***This regulation is under review for 2024 with the intention of mandating that HT leads must be standard OEM or equivalent items (the original intention of the regulation) displaying the manufacturer’s original identification part number/code. The use of competition/performance items, e.g. Magnecor HT leads, will be prohibited. The permitted use of longer standard leads will remain.***

### Spark Plugs

- 233.20.15 Spark plugs MUST be standard single negative-electrode components only. The use of multi-node spark plugs is NOT permitted.
- 233.20.16 Standard heat range sparking plugs MUST be used. Sparking plugs outside the standard heat range are NOT permitted. The standard original NGK spark-plug heat-range value for the Zetec engine is 5. It is therefore permitted to use an NGK 4, 5 or 6, or alternate manufacturers’ cross-referenced equivalents (see following table).

Manufacturer	Hotter Heat No.	Standard Heat No.	Colder Heat No.
NGK	4	5	6
Champion	16, 14	12, 11	10, 9
Bosch	9	8	6, 7
Denso	14	16	20

### General

**233.20.17** The use of any other sensor(s) or alternative ignition coils (other than those detailed above), alternative ignition systems, and/or any other method to trigger, distribute, and/or time the ignition, is NOT permitted.

**233.20.18** BriSCA F2 reserves the right to swap a driver's ECU for that of another driver, or a replacement item from stock, at ANY time. Failure to comply will result in immediate disciplinary action and a lengthy ban as detailed in the Technical Infringement Penalties section of these regulations.

**233.20.19** BriSCA F2 reserves the right to exchange and/or interrogate ANY ignition components at ANY time. If an ECU has been tampered with in ANY way, the driver will be subject to immediate disciplinary action and a lengthy ban as detailed in the Technical Infringement Penalties section of these regulations.

### 233.21 Fuel pump

**233.21.01** Any fuel pump is permitted.

### 233.22 Cooling System

**233.22.01** The single standard production water pump and housing, as fitted to the permitted 2.0-litre Zetec engine types detailed above, MUST be retained and used. Modification to the water pump drive, its rotational speed, and direction are permitted only in accordance with the regulations below.

**233.22.02** The use of a reverse water pump impeller is permitted.

**233.22.03** Any reverse water pump impeller MUST retain 6 blades, as per the original Ford water pump fitted to the engine.

**233.22.04** Any reverse water pump impeller MUST be fitted to the standard water pump.

**233.22.05** ONE of the following drive pulleys MUST be used on the water pump:

- (1) The original unmodified standard Ford pulley.
- (2) A modified standard Ford pulley – The original standard Ford pulley may be modified to add material for the purpose of drive-belt retention. Removal of original material is NOT permitted.
- (3) The BriSCA F2 approved/supplied replacement pulley – Modification of this item is NOT permitted.
- (4) A replacement pulley manufactured for Zetec engines used on oval circuits – Any such pulley MUST be (i) comparable in design to the BriSCA F2 approved pulley, (ii) at least the same diameter (NOT smaller) across the driven surface as the original Ford component, and (iii) weigh a MINIMUM of 400g.

#### **Note for 2024**

- **The requirements for any non-BriSCA F2/SSCA replacement pulley are under review for 2024 following observation of examples of pulleys outside of the spirit of the regulations. The intention is to mandate stricter specifications to rein-in and prevent the development/manufacture of performance enhancing pulleys, e.g. those incorporating unnecessary holes that reduce the outer rotational mass, or designs to improve performance over the basic BriSCA F2/SSCA item. The requirement for any such replacement pulley to be approved prior to use is also being considered.**

**233.22.06** The fitment of a single additional idler pulley, for the express purpose of reversing the direction of an unmodified water pump to the opposite of the crankshaft, is permitted. Any such single pulley MUST be fitted using a bracket bolted to existing engine bolt holes only. The drilling of additional holes for mounting a bracket is NOT permitted.

**233.22.07** The use of any water pump to circulate or assist in the circulation of coolant liquid, other than the single standard pump specified above, is NOT permitted.

**233.22.08** Any mechanical fan MUST be securely fitted to either the water pump or the crankshaft.

**233.22.09** The fitting of a mechanical fan to additional pulleys and/or brackets, is NOT permitted.

**233.22.10** Any thermostat housing is permitted.



### 233.23 Engine Sealing

- 233.23.01** An appointed scrutineer may require the engine to be sealed at a race meeting as part of the scrutineering procedure.
- 233.23.02** Wire seals will be used to seal engines by way of the removal of a number of bolts securing the camshaft cover to the cylinder head, and the sump to the block. Where it is not possible to use a wire seal, e.g. with captive bolts, paint will be used as an alternative.
- 233.23.03** Additional seals will be fitted as follows:
- The bell-housing will be sealed to the engine by removing two bell-housing bolts and replacing with wire seals.
  - The carburettor will be sealed to the inlet manifold, and the inlet manifold to the cylinder head, by the use of paint.

### 233.24 Engine Covers

#### Cam-Belt Covers

- 233.24.01** Modification, or removal of the cam-belt covers, or replacement with an alternative design, is permitted.

#### Camshafts Cover

- 233.24.02** Modification and/or replacement of the camshafts cover assembly is NOT permitted, unless stated below.
- 233.24.03** Blanking off the original camshafts cover breather outlet on the right (fence) side of the cover over the intake camshaft is permitted.
- 233.24.04** Installing a single alternative breather outlet on the intake camshaft section of the cover is permitted, but only if the original outlet has been blanked off.
- 233.24.05** Installing an additional or alternative single breather outlet on the exhaust camshaft section of the cover is permitted.
- 233.24.06** Linking together the two permitted breather outlets on the camshafts cover is permitted. Examples are illustrated in Technical Diagram 21.

#### Technical Diagram 21

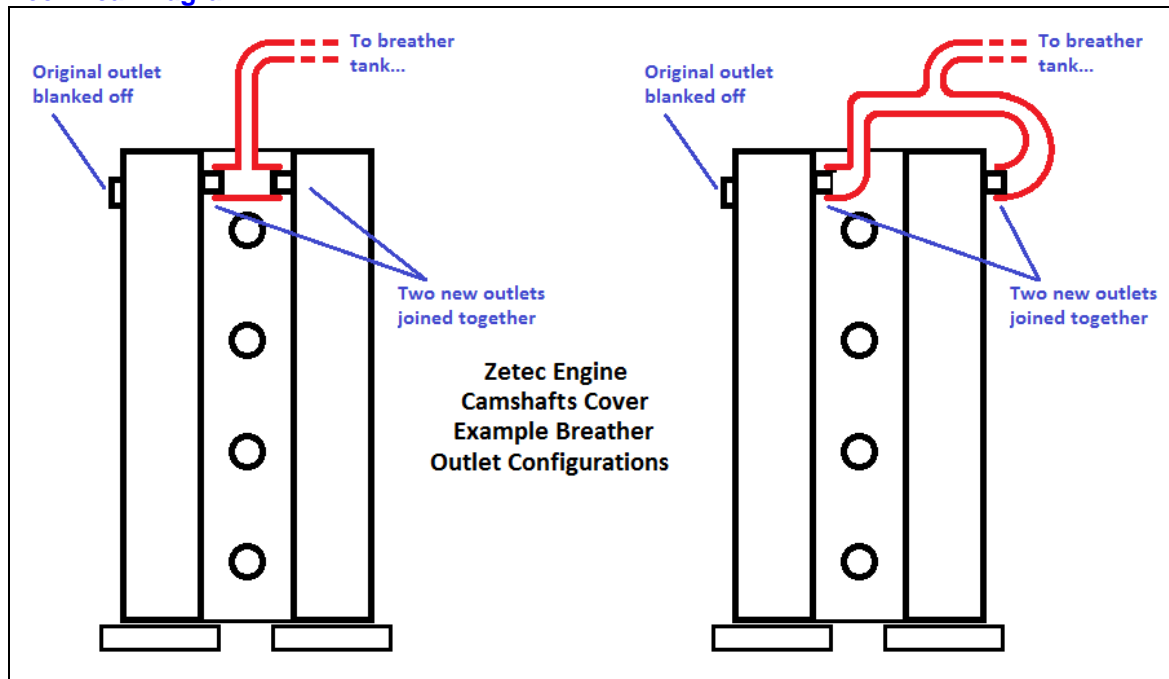

#### Oil Filler

- 233.24.07** Blanking off the oil filler cap is permitted.

#### Ignition Leads Cover

- 233.24.08** The fitting of a light-weight cover over the ignition leads, to prevent the ingress of shale/water, is permitted.
- 233.24.09** Any ignition leads cover may be part of a modified cam-belt cover (see above), or a separate component, however it MUST only be fitted using existing unmodified camshaft cover fixings, or other standard original fixing locations on the cylinder head.



## **234 Safety Equipment**

### **Driver Protection**

**234.01** Refer to the ORCi “Safety Equipment Specification Regulations” referenced in Chapter 15 for details of mandatory driver safety equipment.

### **Race Receivers**

**234.02** A Race Receiver MUST be used in ALL races, practise, and qualifying sessions.

**234.03** The driver’s Race Receiver MUST be switched on and operational at ALL times when on the racetrack, enabling direct one-way wireless communication between a nominated official and all drivers.